

# Retail Fitout Manual

2023.

# Contents

<b>1.0</b>	<b>General</b>	<b>01</b>						
1.1	Introduction	01	2.2.15	Fire Protection Spinkler system	12	3.3.1	Work flow	21
1.2	Project Description	01	2.2.16	Emergency Lighting System	13	3.3.2	Works Execution	22
1.3	Purpose of the Manual	03	2.2.17	Emergency Power System	13	3.3.3	Work Permit & Passes	22
1.4	Scope of Fitout Services	03	2.2.18	Kitchen & Toilets	13	3.3.4	Permit To Work Request	22
1.5	The Fitout Delivery Manager	03	2.2.19	Grease Traps	13	3.3.5	Premises Access	23
1.6	Project Team Directory	04	2.2.20	Treated Fresh Air Intake	14	3.3.6	Precautionary Measures	23
			2.2.21	Utilities	14	3.3.7	Inspection of Works	23
<b>2.0</b>	<b>Design Criteria</b>	<b>05</b>	2.2.22	Electrical Loads	15	3.3.8	Testing & Commissioning	24
2.1	Public & Common Area Spaces	05	2.2.23	Telephone & Data Communication	15	3.3.9	Labelling of Equipment	24
2.1.1	Lift Lobby Area & Main Corridor	05	2.2.24	Security Devices	15	3.4	Work Completion & Occupancy	24
2.1.2	Washrooms	05	2.2.25	Food & Beverage Retailers (F&B)	15	3.4.1	Final Inspection	24
2.1.3	Lobby, Reception & Entrance Areas	05	2.3	Design Criteria – Interior Design	16	3.4.2	Testing & Commissioning Data	25
2.1.4	P2, P3, & The Plaza	05	2.3.1	Architectural	16	3.4.3	Defects Liability Management	26
2.1.5	Fire Stairs	05	2.3.2	Structural / Civil	16	3.4.4	Handover of Leased Premises	26
2.1.6	Access to Common Services	05	2.3.3	HVAC System	18	3.4.5	Handover Documents	26
2.2	Design Criteria – Retail Space	05	2.3.4	Fire Protection Works	18	3.4.6	Takeover of Vacated Premises	26
2.2.1	Lease Premises	05	2.3.5	Electrical Works	18	3.4.7	Liability	26
2.2.2	External Facade	06	2.3.6	Plumbing & Drainage Works	19	3.4.8	Indemnities	26
2.2.3	Signage	07	<b>3.0</b>	<b>Fitout Process</b>	<b>19</b>	<b>4.0</b>	<b>Fitout Rules &amp; Regulations</b>	<b>27</b>
2.2.4	Flooring	08	3.1	Process	19	4.1	Insurance & License	27
2.2.5	Ceilings	08	3.1.1	Preliminary Planning	19	4.2	Working Hours	27
2.2.6	Partition	08	3.1.2	Design Submission & Approval	19	4.3	Breach of Rules	27
2.2.7	Materials	09	3.2	Fitout Process Details	20	4.4	Contractor's Conduct	27
2.2.8	Lighting	09	3.2.1	Detail Planning	20	4.5	Protection Measures	28
2.2.9	Window Coverings	09	3.2.2	Fitout Coordination Fees & Security Deposit	20	4.6	Dust & Noise Emissions	28
2.2.10	Windows / Glazing	09	3.2.3	Limiting Conditions	20	4.7	Temporary Hoarding Specification	28
2.2.11	Demising Walls	10	3.2.4	Design Submission & Approval Procedure	21	4.8	Vehicle Access & Material Delivery	29
2.2.12	Sub-Division of Space	11				4.9	Storage & Handling of Materials	29
2.2.13	Air Conditioning / HVAC	11	3.3	Fitout Execution Procedure	21	4.10	Waste Disposal & Debris Removal	30
2.2.14	Fire Detection & Alarm System	11				4.11	Wet Area Works	30

4.12	General Works	31
4.13	Temporary Fire Protection	31
4.14	Temporary Electrical & Water Supply	31
4.15	Indoor Air Quality	32
4.15.1	Ventilation Requirements	32
4.15.2	Air Quality During Fitout	32
<b>5.0</b>	<b>General Requirements</b>	<b>32</b>
5.1	Adhesives / Glue & Sealants	32
5.2	Paints & Coatings	33
5.3	Carpet Flooring	33
5.4	Ceilings	33
5.5	Acoustic Comfort	33
5.6	Interior Finishes	34
5.7	Lighting Fixtures	34
5.8	Water Flow Fixtures	34
5.9	Material & Resources	34
5.10	Smoking Control Policy	34
<b>6.0</b>	<b>HSE Forms</b>	<b>34</b>
<b>7.0</b>	<b>DDA Fitout Guidelines</b>	<b>34</b>
<b>8.0</b>	<b>Fitout Forms</b>	<b>34</b>
<b>9.0</b>	<b>BTU Meter Installation Guide</b>	<b>34</b>
<b>10.0</b>	<b>Chilled Water Connectivity, Consumption And Account Management</b>	<b>34</b>
<b>11.0</b>	<b>Timeline</b>	<b>37</b>

## Abbreviations:-

- AC - Air Conditioning
- AMC - Annual Maintenance Contract
- ASHRAE - American Standard Heating, Refrigeration & Electrical
- BMS - Building Management Services
- BTU - British Thermal Unit
- DB - Distribution Board
- CBS - Central Battery System
- CHW - Chilled Water
- CPT - Central Park Towers
- DCD - Dubai Civil Defence
- DCL - Dubai Central Lab
- DDA - Dubai Development Authority
- DEWA - Dubai Electricity & Water Authority
- DIFC - Dubai International Financial Centre
- DM - Dubai Municipality
- EPA - Environmental Protection Agency
- F&B - Food and Beverage
- FACP - Fire & Access Control Panel
- FDM - Fitout Delivery Manager
- FLS - Fire & Life Safety
- FRP - Fibre Reinforced Plastic
- GF - Ground Floor
- HPL - High Pressure Laminates
- HSE - Health, Safety & Environment
- HVAC - Heating, Ventilation, Air Condition
- KWP - Kitchen Waste Pipe
- MDF - Medium Density Fiberboard
- MEP - Mechanical, Electrical, Plumbing
- NFPA - National Fire Protection Authorities
- NOC - No Objection Certificate
- P1, P2, P3 - Podium 1, 2, 3
- PMT - Property Management Team
- PTW - Permit to work
- QHSE - Quality, Health, Safety & Environment
- RCP - Reflected Ceiling Plan
- SIV - Supervisory Isolation Valve
- SMDB - Sub Main Distribution Board
- TAB - Testing Adjusting Balancing
- VOC - Volatile Organic Compound
- ZCV - Zone Control Valve

## 1.0 GENERAL

### 1.1 INTRODUCTION

Arady Developments LLC, the Landlord of Central Park Towers (CPT), is a joint venture between Dubai Asset Management and Deyaar Developments. CPT is the largest single-owned office development in the DIFC free-zone.

The Building design offers maximum floor plate efficiency built to a high standard; with CAT A fitted, CAT B furnished and Shell & Core offices available. Over 100,000 sq ft of retail space that provides the Tenants with the opportunity to shop, dine and socialize. Retail outlets are located in the Retail Walk, GF, Podium 2 and 3.

### 1.2 PROJECT DESCRIPTION

The Building is located in the DIFC, comprises of:

- 4 Basement Floors ( Tenant Parking )
- Ground Floor ( Retail + Visitors Parking )
- 2 Podium floors ( Retail + Residential Parking )
- The Plaza ( Outdoor Concourse )
- 45 floors Office Tower
- 47 floors Residential Tower

#### BASEMENT FLOORS:

The basement can accommodate 2122 parking spaces including dedicated bays for People of Determination, Electric Charging Vehicles and Preferred Parking bays on

each floor along with MEP services. There are a double-point vehicular access / egress to / from the basement parking with entry from the west side and exit from east side for ease of traffic flow & exit. Access is controlled by a card access barrier system.

#### GROUND FLOOR:

The GF accommodates the main entrance lobby of the office tower, which is designed as a generous space with the reception and waiting area, leading to the lift lobby. There are two rear exits leading to parking area. Also located at this level are Male and Female Toilets. The peripheral space consists of 301 visitor parking bays including 17 dedicated bays for People of Determination which are controlled by a card access barrier system. There is a token machine for all visitors to gain access to the GF car park, with the first 3 hours free and a charge per hour applied thereafter.

#### PODIUM FLOORS:

Podium 2 & 3 are part of the Retail Walk and consists of retail units of varying sizes, male / female toilets, prayer rooms on P2 and parking area for 673 residential parking spaces on P1. Also MEP service rooms are located in this car parking zone.

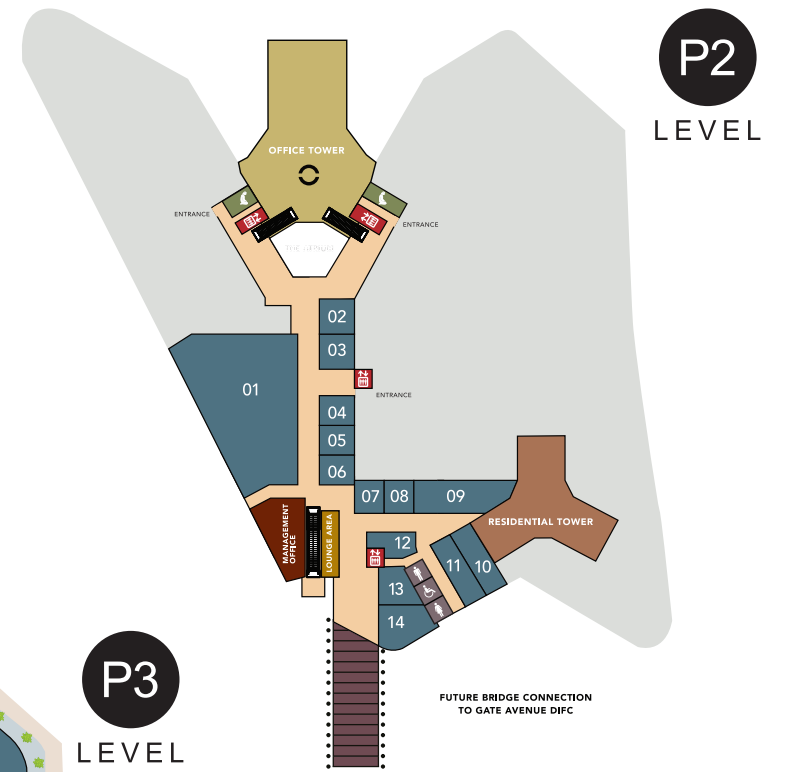
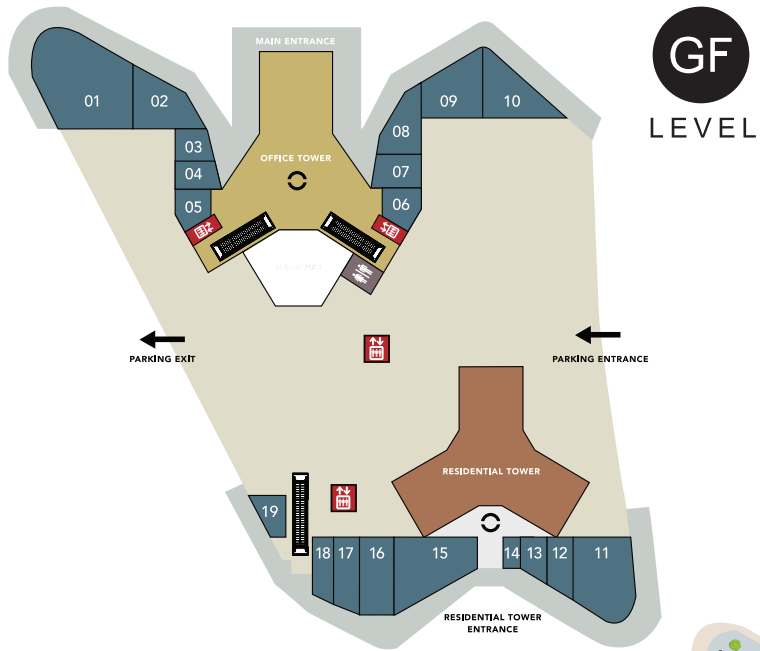

## ROOF LEVEL:

The roof level comprises of services rooms, chillers and overhead water storage tanks. This is generally non-accessible area and is restricted to the Building services and maintenance team only.

### 1.3 PURPOSE OF THE MANUAL

This Fitout Manual (Manual) contains general information relating to CPT retail leased spaces in the entire Premises / Building, but more particularly, it contains requirements and guidelines to be followed by Tenants and their Fitout Contractors when carrying out the installation of interiors within their leased Premises. This document relates to Fitout process for retail Premises only.

This Manual is provided in order to set out the responsibilities of the Tenant, Fitout Contractors and Landlord (including agents of the landlord) in order to facilitate completion of the Tenant's Fitout works in an efficient and timely manner and to provide clarity to each party as to their role in the process.

This Manual is intended for all new and existing Tenants of CPT and its affiliates that will be undertaking Fitout works, upgrades or retrofits of the Premises (Works). All sections of this document should be read and understood by the Tenant and his Contractor / s. This document should also be read in conjunction with the Tenant's Lease Agreement and the terms defined therein. In the event of any discrepancies between the terms and conditions of this Manual and those of the

Tenant's Lease, the Tenant's Lease shall take precedence. Nothing in this Manual shall relieve the Tenant of any responsibilities as stated in the Lease.

Please note that it is the responsibility of the Tenant and his contractor / s to check all given dimensions on site prior to commencing detailed design drawings, documentation and during Fitout process. The Landlord or Property Manager shall not be held responsible for abortive design or construction work through failure by a Tenant to conduct a thorough site check or to carry out due diligence on technical specifications and validation of base built MEP services.

### 1.4 SCOPE OF FITOUT SERVICES

The Tenant shall ensure that the Tenant's Contractors have a copy of this Manual and that they comply with the requirements detailed within as applicable to them. The provisions contained in this Manual form part of the Lease Agreement (Lease) between CPT and the Tenant, unless otherwise agreed in writing. If any event or any matter herein conflicts with any provision(s) of the Lease, the Lease will take precedence. This Manual shall apply to all leased retail units within the jurisdiction of CPT for all Works, which includes but is not limited to:

- Architectural / Partitioning works
- Structural addition / modification works
- Interior finishes such as flooring, ceiling, painting etc.
- Mechanical, Electrical, Plumbing / drainage (MEP)

works modification

- Telecommunication and data works
- Gas connection works
- Signage
- British Thermal Unit (BTU) Meter installation as per item 9.0 of this Manual

### 1.5 THE FITOUT DELIVERY MANAGER

The FDM will act as an exclusive and sole representative on behalf of CPT and Landlord and shall perform duties as Landlord representative. All project communications and correspondence must be directed to the FDM to seek necessary permissions from the Landlord and Authorities.

During the Fitout period, each Tenant will have a FDM to assist with coordination. If there are any questions about the information contained in this Manual, please contact the FDM, located on-site for official clarification.

The FDM, or his representatives, cannot be held responsible for any inaccuracies and Tenants are responsible for undertaking their own reasonable care and due diligence in their retail design and Fitout that shall be in compliance with Authorities Standards / regulations and requirements.

## 1.6 PROJECT TEAM DIRECTORY

<b>OWNER / LANDLORD</b>	Arady Developments LLC, (Central Park Towers)
<b>FITOUT DELIVERY MANAGER (FDM) -DREES &amp; SOMMER</b>	Sumit Kapoor Mob: 055 599 5845 or 058 520 1989 sumit.kapoor@dreso.com or ali.asgher@dreso.com
<b>SENIOR MANAGER</b>	Holly Smith Mob: 058 932 9052 holly.smith@centralparktowers.ae
<b>FACILITIES ENGINEER</b>	Antony Santhumayor Mob: 055 992 7253 antony.santhumayor@centralparktowers.ae
<b>QHSE OFFICER</b>	Sony George Mob: 056 939 6252 sonyc@deyaar.ae
<b>SECURITY SUPERVISOR</b>	Duty Supervisor Mob: 050 874 5318 securityCPT@uae.g4s.com

## 2.0 DESIGN CRITERIA

This section of the Manual outlines the particular information in terms of architectural, structural and MEP aspects by CPT illustrating various aspects to be followed by the Tenant and the Tenant's Contractors during the Works execution on the Premises.

### 2.1 PUBLIC & COMMON AREA SPACES

#### 2.1.1 LIFT LOBBY AREA & MAIN CORRIDOR

Lift lobbies and main corridor at each level are fitted out and no change is allowed to be made to these areas unless authorized with special approval by Landlord.

#### 2.1.2 WASHROOMS

Washrooms are separate for male, female and disabled persons and are located on P2, P3 and GF. No adjustment shall be made to these rooms.

#### 2.1.3 LOBBY, RECEPTION & ENTRANCE AREAS

The concept design for these areas has been integrated into the overall design and reflects the overall aesthetic's of the community and no change shall be made to these areas.

#### 2.1.4 P2, P3 & THE PLAZA

Retail space on each floor is serviced by 5 service lifts providing access to all podium levels of the Building, and shall be used for this purpose when instructed by FDM. Each lift is linked to the Building security / access system. The maximum load and size of service lifts are as follow:

- PG 1– Ground floor, Retail P2 & all car park levels, up to The Plaza only: Height – 235 cm, Depth –146 cm, Width – 180 cm, Max. Load = 1600 kg.
- PG 2–Basement 4 to The Plaza level only-2 stops only: Height–235 cm, Depth–160 cm, Width – 180 cm, Max. Load = 1600 kg.
- PG 3 – Ground floor, Retail P2 & all car park levels up to The Plaza only: Height – 220 cm, Depth -220 cm, Width – 145 cm, Max. Load = 1275 kg.
- PG 4 & PG 5 – B4, Ground floor Loading / refuse docks up to Retail P2 only: Height – 240 cm, Depth – 250 cm, Width - 200 cm, Max. Load = 2500 kg

#### 2.1.5 FIRE STAIRS

Fire egress stairs are provided in accordance with local Authority requirements. The stairs may be used for inter floor access and for fire egress.

#### 2.1.6 ACCESS TO COMMON SERVICES

Access for maintenance purposes to the Building services installation should not be restricted by installation of any fixtures, fittings or non-dismountable partitions. The Tenant is required to remove / relocate any such items which obstruct access for maintenance of Building installation at the Tenant's cost. In addition, the Tenant should provide adequate access to the ceiling void for maintenance of electrical and mechanical services which are part of the base Building installation, if a non-dismountable type of false ceiling is installed by the Tenant.

### 2.2 DESIGN CRITERIA – RETAIL SPACE

#### 2.2.1 LEASE PREMISES

The floor area has been divided into units as part of the base Building design and is defined in drawings. It is the Tenant's prerogative to provide a design to suit his particular requirements and to propose the interior design and decoration.

All MEP systems are described herein, with provision points for AC systems. All units have been provided with an electrical distribution board, and some units have a provision of a water inlet point, gas and kitchen extract system.

Some walls abutting the common corridor consist of concrete / block work and to other areas are provided with a peripheral glazed facade as per the base Building



design. Some units come with a provision for internal toilet facility. There is an outdoor area which is provided with shade canopies. These areas are available for rent by the adjoining retail outlets only and hence shall be linked to the indoor retail space. All external related furniture in the rented areas shall be provided by the Tenant and design layout to be approved by the FDM and Landlord. Any changes to the landscaping as provided by the base Building design are not accepted. The Tenant shall allow for service access and facade maintenance to when required.

### 2.2.2 EXTERNAL FACADE

The retail spaces as defined in the lease drawing are enclosed by a glazed facade with pre-determined access doors which are part of the base Building design. Request for change to the facade or door locations may be considered by the Landlord. Signage to retail is to be located in areas that do not affect other retail, office space or public areas. The location, size, type, fonts, etc. is subject to the approval of the FDM, Landlord and DIFC.

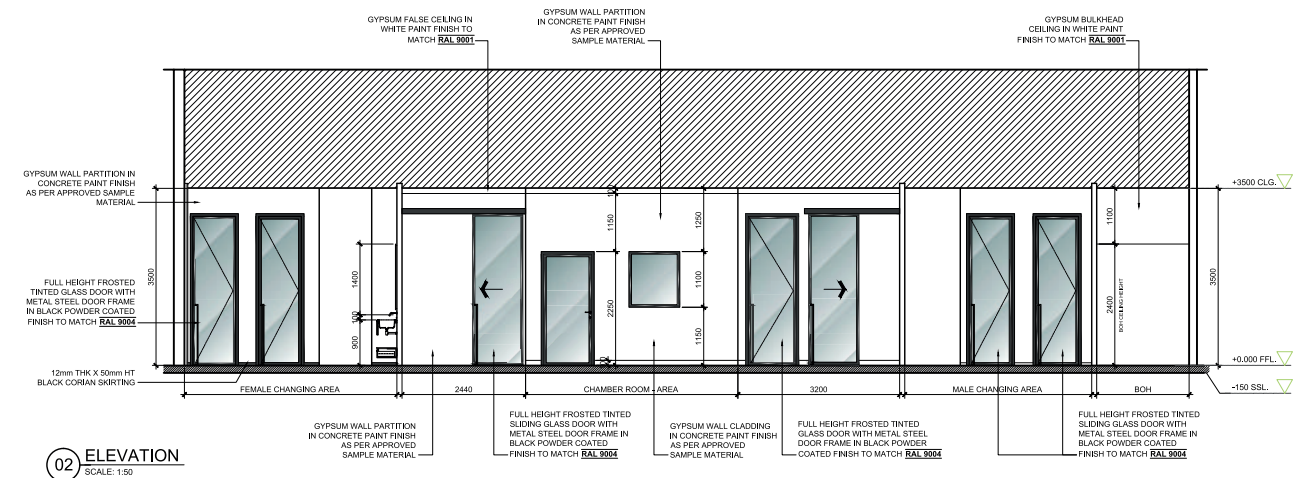
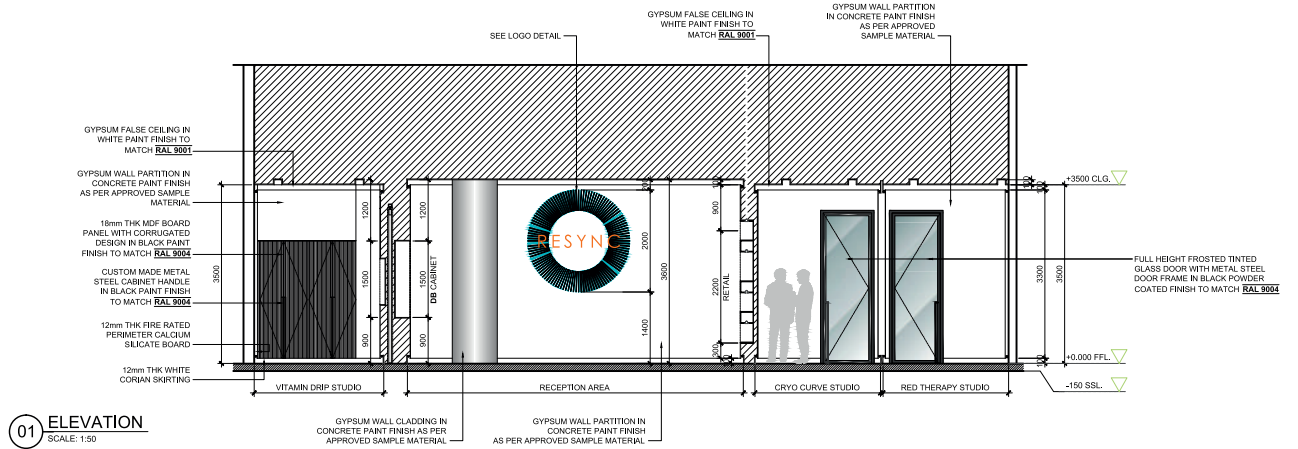

00A\_12/12/2019 11:31:14 AM

### 2.2.3 SIGNAGE

No display of neon sign or advertisement, etc., will be allowed if these can be seen from the face of the curtain wall, window or external wall unless otherwise approved in writing by the FDM. However back-lit in podiums & front-lit in external areas LED signage are allowed subject to approval of the signage sample by the FDM & Landlord.

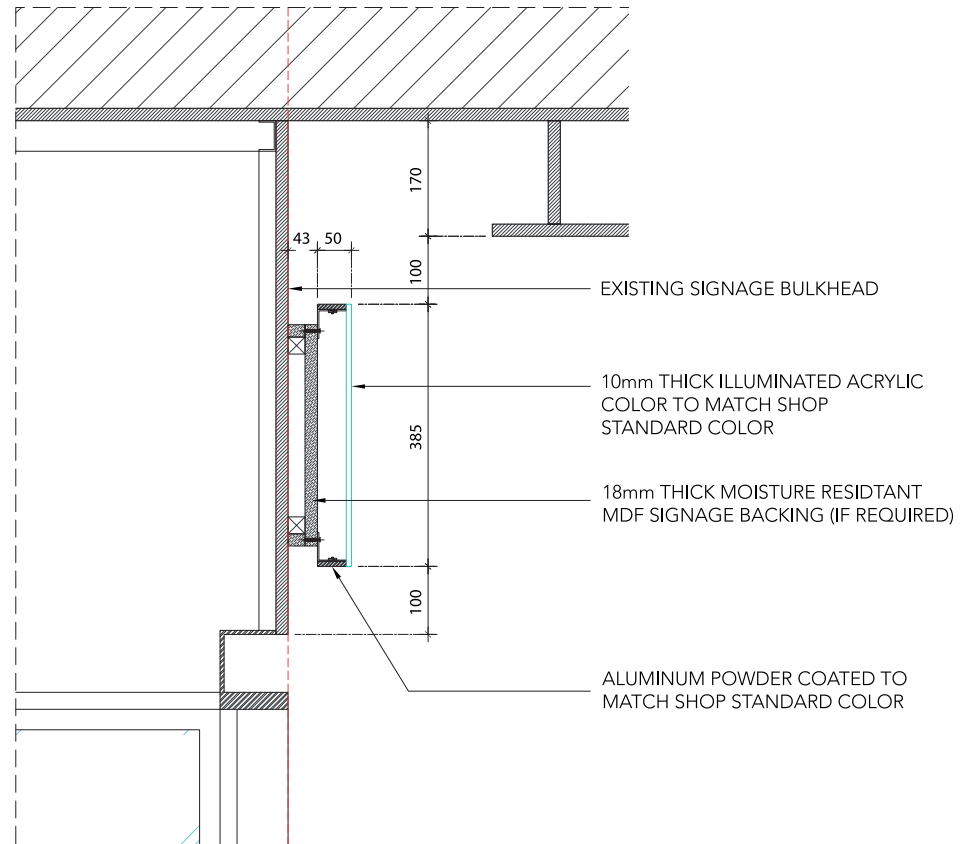
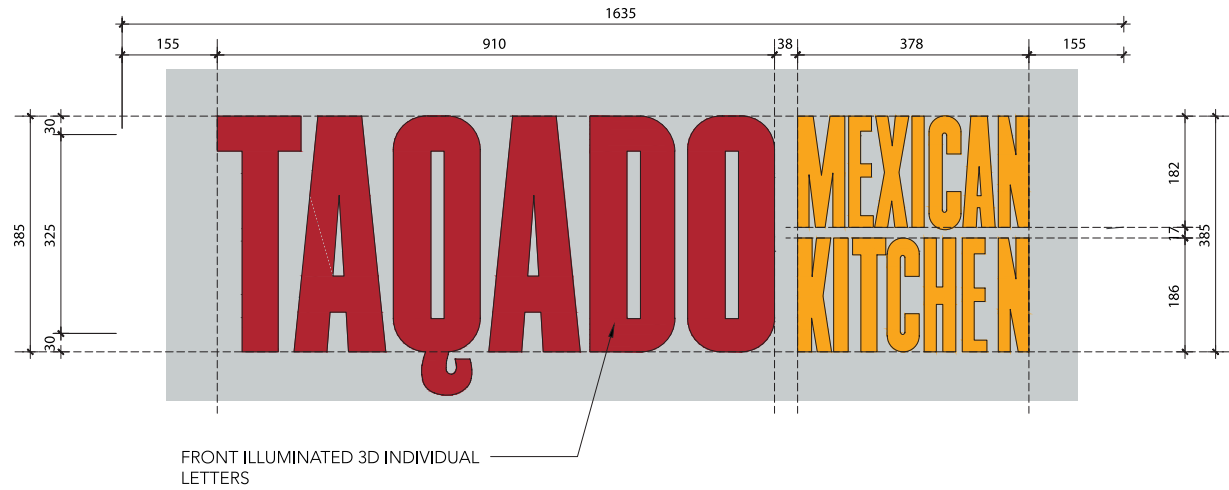

#### 2.2.4 FLOORING

The leased Premises are provided without finishes (shell and core). Tenants must install a proprietary raised floor system which shall be level with the external entrance walkways. No thresholds, reducer strips or other transition devices shall be permitted at the intersection of the public area tile flooring. The flooring must be able to withstand loadings as per tenant use / tenant partitioning / concentrated loads / uniform loads and impact loads.



All power must be fireproofed in accordance with NFPA and local DDA. When fixed to the slab it must not be intrusive or have a detrimental effect on the Building structure. No penetrations including chases and saw cuts in the slab are permitted unless agreed in writing by the FDM and carried out by an approved Contractor. If a Tenant chooses to create a wet area in the designated locations it must be fully waterproofed and is subject to the FDM's directions, specifications inspection and approval. Only light weight screed is allowed subject to approval of FDM.

#### 2.2.5 CEILINGS

The floor-to-floor height varies from 3250mm - 8000mm. The clear height is to match the frame but may be dropped internally to match interior design requirements and should be in line with statutory Authority requirements.

The Tenant has to make provision for a suspended false ceiling as per his particular requirements along with provision of AC diffusers, light fittings, all MEP services including smoke / fire detectors, sprinklers etc.

All internal partitions shall be of non-combustible material and in addition to this all fire and life safety regulations must be respected in accordance with the Building codes and local Authority requirements.

All works to any fire & life safety services must be verified by the CPT appointed Fire Services Team or the appointed agency and approved by FDM, prior to work commencement.

All ceiling systems will be accessible and the Tenant will incorporate sufficient access panels to allow the Landlord to maintain the base build MEP systems, including but not limited to, wet services pipes, valves, fire dampers, ceiling void smoke detectors, drainage lines, electrical installations. The FDM is to inspect all MEP services above ceiling prior to final closure.

#### 2.2.6 PARTITIONS

• All partition walls must be of a demountable type, i.e. gypsum sandwich panel with lightweight plaster core or gypsum / cement board (with fibre wool insulation layer for soundproof wall), timber partitions, partial or fully glazed panels and other light weight panels. All materials used for partitioning and for fit-out of the tenanted Premises must conform local Authorities current DCD Fire Resistant Standards.

• Only in special circumstances where security or fire rated enclosures are absolutely necessary will lightweight concrete partitions or other 'wet trade' construction method be permitted. Where, this form of construction is proposed, the tenant will be required to clearly identify the location and construction of the proposed wall. The same shall be substantiated with structural calculations

• Partition walls abutting windows must be positioned against mullions. Tenants must not secure or fix any fixtures or partitioning onto curtain wall mullions. Drilling and / or fastening of screws, inserts, etc. On to mullions, window sills, tie-strut aluminium covers, etc. are not permitted. Tenants must not place anything (partitions, furniture, etc.) near or at any windows in such a manner as to prevent future replacement of window panes.

• All fixed partitions and built-in cupboards terminating at window panels must not hinder the full opening of any operable window panel. All sideboards and / or cupboards located under windows must not extend in height above the window sill.

### 2.2.7 MATERIALS

Alterations, additions, reinforcement or modifications to the base Building designed structure, piping, conduit or ductwork to accommodate the Tenant's work shall not be performed without, in each instance, obtaining prior FDM approval. The Tenant shall leave the Building structure as strong or in a stronger condition than the original design with finishes unimpaired.

The FDM may require that approved structural or electromechanical modifications be performed by the Landlord's Contractor at the Tenant's expense. The Landlord may further require that engineering analysis, review or design be performed by the Landlord's Engineer at the Tenant's expense.

No structural penetration in either floor slab or wall is allowed without prior written approval of the FDM. Partition work shall be limited to dry-wall installations, timber partitions, partial or fully glazed panels and other light weight panels.

### 2.2.8 LIGHTINGS

There is no provision for integrated light fittings or wiring. All lighting design and wiring shall be in line with DEWA regulations. All wiring shall be provided from the DB and / or Isolator which is provided within the leased area if required to be relocated shall be as per the load schedule and is subject to FDM and DEWA approval.

### 2.2.9 WINDOW COVERINGS

The Tenant may install manually or electrically operated roller blinds as per tenant selection. Compliance of all window coverings shall be as per regulations.

#### FABRIC

The fabric shall be stable, resistant to UV light, periodic cleaning and fraying along its cut edges.

Sun screen fabric is woven vinyl-coated polyester yarn in basket weave pattern to achieve a fabric with an openness factor of 3%.

### 2.2.10 WINDOWS / GLAZING

The Tenant is not permitted to change the material or the colour of the external glazing or aluminum works that form any part of the Premises. The tenant shall clad with MDF or any suitable material and finish the part of windows that are non-glazed but installed with insulation. No solid object of any type may be set to rest on or touch the exterior glazing or on the aluminum window sill. Tenants are requested to ensure that their employees are aware of this requirement.

No items may be hung from, stuck to, or otherwise attached to the glazing or aluminum cladding supports. No penetration punctures or fixing to the curtain wall is allowed. All interior construction must be self-supportive.

### WINDOW GRAPHICS (TEMPORARY)

Once leases are signed there may be a need to cover store front windows. You will be required, at your own expense, to place temporary vinyl graphics on your store front windows during your fit-out period with your branding and stating, "opening soon". All graphics must be submitted to Management for approval prior to printing and installation.



Additionally, retailers that have outside store fronts are required to obtain an NOC from the Management and then submit their graphics to DIFC for approval prior to printing and installation.

### WINDOW GRAPHICS (PERMANENT)



Once retailer is ready to trade, graphics must be replaced with permanent branding and messaging, if applicable. These graphics need to be submitted to Management for approval and outside facing store fronts will need an NOC from Management and submit to DIFC for approval prior to installation.

For permanent graphics, windows cannot cover more than 20% of the window area and vinyl is to be installed on the inside unless requested otherwise by Management.

Retail tenants with exterior store fronts are required to install their store signs outside their leased areas, at their own expense. Sign location, specifications and procedure are determined by Management. Details of sign specifications will be provided.

### 2.2.11 DEMISING WALLS

No penetrations into the common area core walls are allowed. These walls may not be used for fixtures and shelf support. The walls shall be finished by the Tenant and shall be constructed with a minimum 150mm thick with gypsum board double layered fire rated board. The gap shall be filled with double layered Rockwool insulation that shall comply with required sound proof level.

Walls within a tenancy may be modified, used for support or removed, pending approval by the FDM and conforms to all applicable fire regulation.

The Building and demising walls have been designed with a noise reduction rating of 53db. Tenants are not permitted to exceed this level.

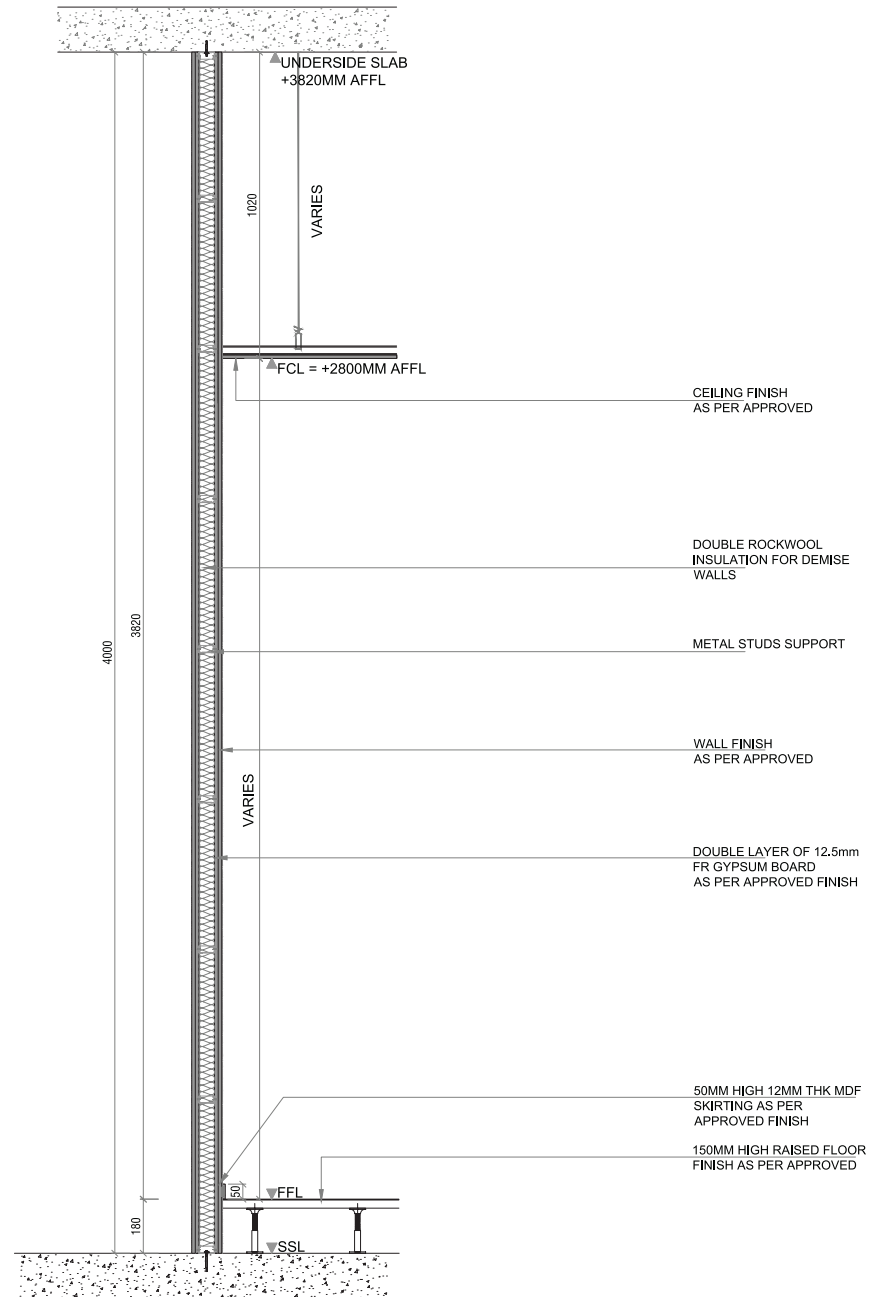

DETAILS OF DEMISE WALL 150MM THICK

### 2.2.12 SUB-DIVISION OF SPACE

Partitioning of the floor space is permitted with prior written approval by the FDM, providing that the partitioning lines coincide with the external wall glazing where they meet the vertical mullions of the façade and do not in any way damage the integrity of the external glazing or the appearance of the Building. Partition walls must align with, and no end of partition shall be built to touch or divide a curtain wall glass pane and no partition shall be supported on the frame of curtain wall system. Partitioning between units has to be fire rated partitions following NFPA and local Authorities regulations.

### 2.2.13 AIR CONDITIONING / HVAC

The leased Premises are provided with chilled water supply provision, and in some instances fresh air and extract system as part of the base build design.

It is the Tenant's responsibility to design the complete AC system which is compatible with the base Building design, seek approval from Authorities as required and obtain prior approval from the FDM before starting any installation. Existing chilled water stub out bypass should be kept intact with additional bypass valve in their unit space.

Phenolic pre-insulated ducts are preferred as opposed to normal pre-insulated ducts. FCU to be interfaced with fire panel to stop in the event of fire incident. All installations must comply with DCD regulations including testing and commissioning of the same and provide the

necessary approval certification to the FDM.

The Tenants are to consider access to the unit for maintenance and repair work. Any further Authority approvals shall be taken by the Tenant.

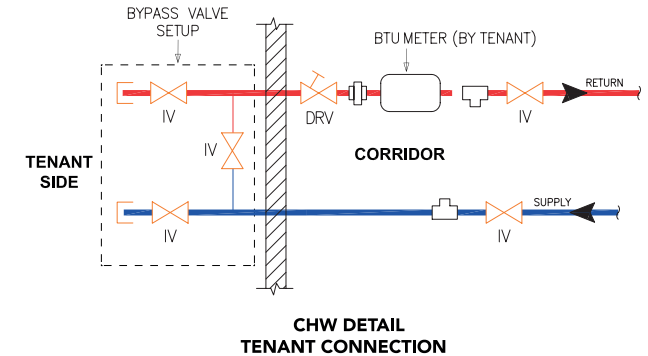

### 2.2.14 FIRE DETECTION & ALARM SYSTEM

As part of base build, the Fire & Lift Safety System (FLS) provided are compliant with DCD regulations and DDA requirements. Each retail space is provided with required number of smoke detectors, and sprinklers. The Tenant contractor shall carryover modifications to existing FLS system to be in compliance with DCD regulations including void detectors in ceiling & below raised floors if the void space is exceeding the limit as per local regulation, and if there are no further available spots on the loops.

An additional fire detection or FACP and 24x7 DCD panel is to be installed by the Tenant that shall be compatible with the base Building Fire Panel system

and compliant with DCD requirements. Suitable access panels are to be provided for future maintenance and repair.



Upon completion of the installation of the Tenant's FACP, the Tenant is required to connect to the main detection panel of the Building.

- The Tenant to submit a copy of the functional test certificate of the system to the FDM
- Tenant is required to submit a copy of the cable continuity test certificate to the FDM
- Tenant shall arrange for the installation, testing and configuring / commissioning of an interface unit to connect their fire detection and alarm system to the main system of the Building and arrange to obtain the required Authority approvals.

The Tenant shall be responsible for obtaining an AMC for the same, at the Tenant's expense from a DCD approved Fire Service Contractor. FDM will advise who the Fire Service contractor is.

The Tenant is also responsible for obtaining and servicing the fire extinguishers within the Leased premises.

The Tenant is required to show proof of the maintenance of the fire panel and associated system to DCD when renewing their Lease Agreement / Trade License. The Tenant is also required to install 24x7 direct link to DCD so that the panel is monitored independently. Without both of these requirements the lease agreement is not renewed.

If the PMT notes a fault on a Tenant's panel, the Tenant will be given 24 hours' notice to rectify the matter, after which time, the Landlord will undertake to rectify the same at the Tenant's expense.

Please note that the fire panel does not specify the nature of the fault. The main fire panel does record a log of faults. However, these are automatically overwritten as the memory reaches capacity. The fire panel log can be viewed manually to log the date and time of any registered faults. It is the responsibility of the Tenant to arrange to view the panel if any visual evidence is required from the log.

The fire panel should be located as per DCD requirements / approvals and shall be accessible to the Landlord, Security / PMT. The Tenant shall provide a copy of the key for electromagnetic override to the Landlord.

## 2.2.15 FIRE PROTECTION - SPRINKLER SYSTEM

The Building is fitted with a sprinkler system. In the case where full height partitioning is installed by the Tenant, the sprinkler head layout shall be planned in a way that sprinkler protection and coverage of each partitioned area is maintained. Such modifications will be subject to all DCD approval requirements and Landlord approval.



Upon completion of the fire fighting system design drawing, and after obtaining DCD approval, the alterations and changes to existing fire fighting sprinkler system must be carried out by licensed fire fighting contractor servicemen in coordination with and subject to the approval of the FDM / QHSE. A fire impairment permit has to be filled in and signed by the fire contractor carrying out the work and approved by the FDM / QHSE prior to commencement of work. The fire service specialist shall ensure closure of ZCV prior to commencement of fire fighting system modification and further open the same once work is completed. The Fitout Contractor shall get the ZCV work inspected / signoff from FDM / QHSE for this particular work. In the

event ZCV is not installed to the retail unit, the Tenant shall install SIV and connect the same to FACP system. Method statements, risk assessment and work schedule are to be agreed with the FDM as the Work will involve draining the entire system of the floor or Building and involves considerable preparation. Additional security is required and safety risks need to be considered.



In the event of fire fighting pipe network inside lease unit is passing to adjacent unoccupied Shell & Core units, then the Tenant is responsible to modify and add additional sprinklers in compliance with DCD regulation in both the units.

Fire Impairment Permit has to be filled in and signed by the fire servicemen carrying out the work and approved by the FDM / PMT / QHSE prior to commencement of work. The fire service specialist shall ensure closure of ZCV prior to commencement of fire fighting system modification and open the same once work is completed. The Fitout contractor shall get the ZCV work inspected / signed off from FDM / QHSE for this

particular impairment work.

Each Tenant shall provide their own fire extinguishers and install in appropriate locations as advised by their consultant and they must be regularly serviced by licensed fire servicemen. The Tenant will be responsible to obtain DCD approvals.

### 2.2.16 EMERGENCY LIGHTING SYSTEM

Each leased space is provided with provision for central emergency lights system and Tenants are to design the location of emergency lighting as per their individual requirements.

The Tenant has to further install a self-contained CBS in order to ensure power-on during a power failure of the unit internally and Landlord provided CBS is functional in the event of a Building power failure. The Tenant shall ensure, both systems comply fully with DCD regulations. The Tenant will be responsible to take the DCD approvals.



### 2.2.17 EMERGENCY POWER SYSTEM

There is a provision for emergency power supply as part of the base build system. Tenants are not permitted or provided any supply from this system. All Tenants should provide their own uninterrupted power supply backup systems.

### 2.2.18 KITCHEN & TOILETS

Fitout of kitchens and toilets would require a proposal from the Tenant and a written approval from the FDM. In such cases, water proofing membrane shall be installed, along with extract systems ecology unit type and all relevant details must be submitted for approval. Some units are provided with a provision for internal toilet connection and the tenant is expected to adhere to the location and provide their own toilet installation proposal that is subject to FDM approval.

### 2.2.19 GREASE TRAPS

Certain Food & Beverage tenants tenancies have connection pipes to the centralised grease traps through the KWP. All Tenants using cooking oils must connect this kitchen drainage system through the KWP system and need to provide the FDM with all technical information for approval prior to connection. In addition to the centralized grease traps, the Tenant shall install their own grease trap and connect the same KWP as per the Landlord and DM regulation.





### 2.2.20 TREATED FRESH AIR INTAKE

Certain retail areas do not have fresh air intake provisions therefore the Tenant shall install adequate capacity of air-intake fan based on their individual system requirement, connect it to CHW system in order to get treated fresh air in the Premises. The fresh air unit shall be ceiling mounted or fixed to the external façade louver with additional sand trap louver.

### 2.2.21 UTILITIES

#### BTU METERS

The Building has provision for one BTU meter per each leased unit in order to monitor CHW consumption. The chilled water is billed on a monthly basis directly to the Tenant by service provider (Logic Utilities) at an agreed rate and based on the consumption of their leased area. The Tenant is responsible for the BTU meter connection, meter supply and installation costs as indicated in contents 8.0 BTU meters installation guidelines.



### ELECTRICITY METERS

Each leased unit has provision for one utility meter. Tenants who are occupying a space with more than one unit will need to pay against the power consumption in each space separately. All Tenants will need to apply to DEWA as part of the fit-out process.



### WATER METERS

Some leased units are provided with a provision of water supply and a BMS meter as part of the Base Building System. Tenants that have proposed wet areas / pantries would need to get approval from DEWA. The cost of

such approvals and permits shall be borne by the Tenant and note that the Tenant shall be billed directly by the Landlord. For Fitout period usage, the tenant has to install temporary meter & pay the consumption charges accordingly.



### GAS METERS

Certain retail tenancies have a LPG gas provision. Gas installation details must be submitted to the FDM. Gas meters will be provided by an approved and exclusive gas supplier and billed monthly in arrears by the Landlord's gas supplier to the Tenant.



### 2.2.22 ELECTRICAL LOADS

All retail areas are provided with service connections for electrical power. The space is provided with an electrical isolator and of approved capacity (for lighting and equipment). Electrical load schedules can be provided from the Landlord and it is strongly recommended to review this prior to Lease sign off. It will not be possible to provide any additional power load to individual units and this should be taken into account in the design process.

### 2.2.23 TELEPHONE & DATA COMMUNICATION

There is a general provision for data point (containment only) in each outlet as shown in the drawings. The Tenant will be responsible for service application, data (fiber optic) cabling from MDF room and payment to the relevant service provider. All data communication systems shall be submitted to the FDM and would require review and approval.

### 2.2.24 SECURITY DEVICES



The Tenant shall submit security system drawings and schematic diagram for any such device proposed to be installed. The Tenant should inform the Landlord of their intention to install access control for their main entrance door as it should be compatible with base build FACP / 24x7 panel to open automatically in the event of fire.

### 2.2.26 FOOD & BEVERAGE RETAILERS (F&B)

A) Walls: It is mandatory to have island kitchen layout whereby kitchen and preparation area shall be at the center of the shop layout. Minimum set back of 2.00m from back area glazing shop front to be left. The Tenants preparation area and kitchen walls shall use tile, FRP or stainless steel sheet.

*All demising partitions and kitchen enclosures must meet fire-rating code requirements of UAE Fire Code.*

A wall separates the service area from the preparation area. These walls must prevent views into the preparation area either by a self-closing door or by a staggered “blind” wall. The tile grout surface shall be sealed in areas where moisture or grease producing equipment are located. The Tenant shall provide a back wall completely separating the service area.

*This wall should be as per UAE Fire Code fire-rated and full height up to soffit of roof slab.*

B) Floor: Flooring in the preparation / kitchen area shall be washable and resistant quarry tile. Vinyl tile is not

permitted. Raised flooring in F&B area is only allowed in kitchen and preparation areas subject to Landlord approval. However most kitchen areas have dropped slab for drainage system to be filled with rigid insulation board, sand bedding or light weight / foam concrete to level the finished floor level.

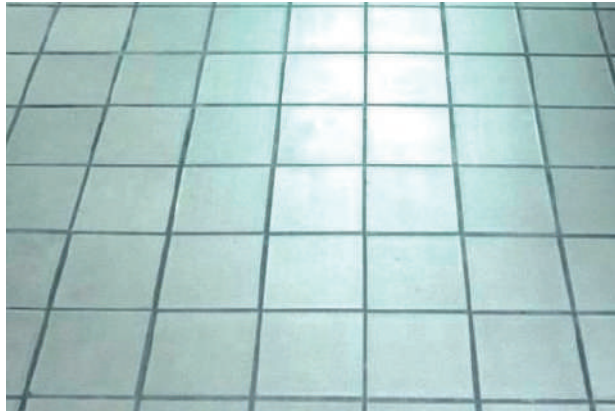

C) Counter: Direct visual exposure of incandescent bulbs and / or fluorescent tubes is not permitted. Ceiling system within the counter and service area shall not be lower than 3000 mm from finished floor.

D) Kitchen Installations: Wet chemical suppression system should be installed for the kitchen hood if gas fired kitchen equipment is used. Proper kitchen extract and makeup air system shall be provided with necessary duct works, cleaning access etc. Extract and make-up air flow rate is to be substantiated with design calculations. The Tenant wishing to install a kitchen extract system must submit a complete set of shop drawings to the FDM / Authorities for approval prior to commencing the

work on site. All kitchen extract systems must be fitted with the DM approved ecology unit and connected to kitchen hood as per the capacity / requirement of Tenant installed hoods.

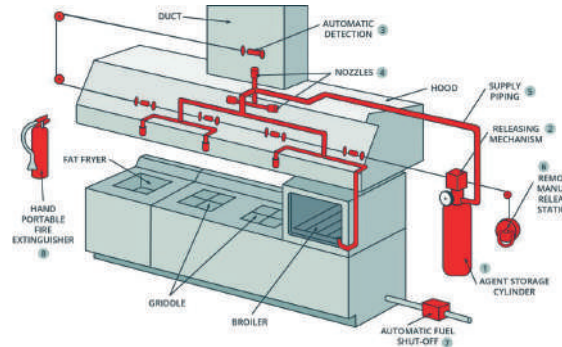

E) The tenant shall be responsible for obtaining all Authority approvals and paying all supply and installation costs. The Tenant shall arrange to install a water filter as per DM standards for cold water supply at meat and / or vegetable preparation / cleaning area.

F) DM Environmental Approval: Tenants are required to submit their Fitout drawings to Dubai Municipality Food & Hygiene Department for their approval prior to submitting it to DDA.

## 2.3 DESIGN CRITERIA – INTERIOR DESIGN

The Tenant shall consider and comply with the following key architectural and structural elements in its interior design and during the Works.

### 2.3.1 ARCHITECTURAL

The Tenant shall follow and comply with the requirement of DDA and DCD regulations with regards to overall design and certain sustainability prerequisites.

All materials including electromechanical for the Fitout works shall be selected conforming to green Building regulations. All materials related to FLS systems need to have a written approval from the FDM prior to commencement of Work.

### 2.3.2 STRUCTURAL / CIVIL

The Tenant shall provide structural drawing layouts and specifications for any changes in the existing Building structures with relevant NOC / approval from the FDM as per the following requirements by the Landlord:

- Standard floor loading is 5KN/m<sup>2</sup>. Should any heavy equipment, such as a safe etc., need to be installed, the Tenant is required to submit 2 options with details such as type, size and weight of the heavy equipment concerned.
- Prior to the commencement of such Works, the Tenant must also appoint a structural engineer for the submission of two (2) sets of drawings for the structural Works required for spreading the load within the allowable limit (together with construction details and structural calculations, etc.) for approval by the FDM.
- The structural consultant's fee involved will be borne by the Tenant. The onus is on the Tenant to prove that the proposed loading is within the allowable loading limits.

- No coring in the structural members such as slabs, columns, core walls, shear walls and beams are allowed in normal cases, however if coring is necessary, as per the Tenants design requirements, then qualified structural engineer should be engaged by the contractor to verify the structural stability of the members and to be confirmed with necessary scanning for rebars & services. All costs involved in engaging the engineer shall be borne by the Tenant.
- No extra loads to be added to the existing structure other than the approved ones during the original approval of the Building. Tenants have the sole responsibility to ensure that at all times no part of the Tenanted Premises is overloaded in any way.
- Tenants must inform the FDM of any area where heavy loading may occur resulting from equipment, storage units, and / or works.
- All materials must have a fire rating as prescribed by the codes and standards. Any damaged fire stopping material must be repaired immediately to approved standards and regulations. Pipes which are installed in these penetrations must meet the required fire rating.
- The gross weight of the partitions, furniture, fixtures, landscaping, water fountains and any new features not to exceed the load assumed during original approval of the Building.
- No demolition of the structural members is permitted.
- All Works to have sufficient allowance for movement of structural members.
- No heavy pre fitout works such as hammering, cutting, assembling etc. to be carried out inside the Building during works, which may impair the structural safety and stability of the Building.
- Changes of wall cladding, floor finishes, thickness of screed, raised floors are all to be clearly mentioned in the drawings to check the conformance of loads with originally approved loads.
- Any perforations through existing demise walls shall be repaired and fire-sealed with products that meet the regulations as defined by DCD. Prior approval from the FDM is required for any floor or wall penetrations. Building Management will request that the locations of these penetrations be checked by the service consultant and the Building structural engineers prior to issuing approval.
- If unavoidable and absolutely necessary, minor alterations (e.g. penetrations through floor slabs for running of pipes) may be permitted. Each case will be evaluated and decided at the absolute discretion of the FDM. Where penetrations through the concrete slab floor or ceiling or service core wall are necessary, all such penetrations shall be suitably fire stopped with appropriate material.
- Partition loads not to exceed 1kN/m<sup>2</sup>
- Any structural connection of Works with the Building's existing structural members to be highlighted on the drawings and subject to NOC / written approval from the FDM and Landlord.

- Any modification of change of usage of Building or part of Building to be clearly highlighted and mentioned in the drawings.
- Any drilling beyond the depth of 25mm to be clearly mentioned and highlighted in the drawings. Written NOC / approval is to be obtained from the FDM, whenever deemed necessary by the Landlord and shall be complainant with DDA regulation.
- Any big openings that are absolutely essential for MEP services through floor slabs or core walls, the contractor shall carryout structural feasibility in conjunction with base build design and submit proposal with structural calculations demonstrating overall structural integrity of the floor and / or Building subject to FDM and / or DDA approval.
- In the event of installation of any steel structure as part of Fitout, the same shall be fire proof protected as per DCD regulation.
- No spray painting work shall affect the existing Tenants of the Building. The Tenant is required to use eco-friendly products to avoid the smell polluting the internal environment. Any hard or soft finishes provided by the respective Tenants shall conform to DDA requirements and be approved by DCD with respect to flame spreading rating.

### 2.3.3 HVAC SYSTEM

All the HVAC systems are designed to be compliant with relevant American Standards Heating Refrigeration and

Electrical (ASHRAE) standards. The indoor environmental condition including the noise level in each zone has been designed with the functional need of space.

### FCU SELECTION

- Selection of FCU's shall be to meet the cooling load calculation with inlet temperature of 5°C and outlet temperature of 14.5°C in order to achieve delta T of 9°C
- FCU selection should be double skin type if the Fitout plan is open type design ( no false ceiling)

### 2.3.4 FIRE PROTECTION WORKS

All the fire protection installations have been designed to comply with relevant NFPA code, UAE Fire & Life Safety code of practice and be approved by DCD.

The Tenant shall comply with the following procedures when designing / modifying existing fire fighting installations, if required by the modification of internal partition or spaces.

- All the rooms / spaces except IT rooms should be covered with sprinkler system if provided with the sprinkler system.
- Computer server rooms and critical rooms shall be provided with FM 200 suppression system or equivalent
- FM 200 to be installed for all server rooms of size above 5 sqm as per Landlord requirement.
- Flooring of server rooms shall be raised with anti static HPL tiles.

The Building is provided with the sprinkler system and

adequate number of smoke detectors and any such modification would require prior approval from the FDM and shall be compliant with DDA regulations.



### 2.3.5 ELECTRICAL WORKS

The design and execution of electrical installations to match interior Fitout requirements must be in accordance with DEWA regulations in general. The Tenant shall comply with relevant standards during the design and installation of electrical services, especially DDA regulations. The key points to be followed during the electrical services design are as follows:

- Component and parts of the installation such as cables, apparatus, equipment and accessories shall comply with the relevant standards and green technology.
- Switches and sockets shall generally be fixed in accordance with mounting heights and the measurement recommended in relevant standards.
- All the electrical symbols used shall be as per British Standards.
- Power savers and use of green technology to be utilized.

- No incandescent or halogen lights are allowed to be installed. The use of LED lights is required.
- If any electrical work are to be undertaken inside the Building electrical room for modification of SMDB / ESMDDB, the contractor is required to obtain de-energizing and subsequently energizing permit that is mandatory to carry out Works.

### **2.3.6 PLUMBING & DRAINAGE WORKS**

The Tenant shall comply with relevant industry standards and practices and DDA regulations. The following shall be implemented when designing / modifying existing plumbing & drainage:

- Coring on floor slab for drain pipe is prohibited if the lower floor is meant for leasing. FDM written approval shall be obtained to core the slab in permissible areas with proper screening.
- Alternatively, drain pump with standby connecting the proposed drain network with the existing drain pipe at higher level should be proposed where coring is prohibited.
- All the wet area should be waterproofed and tested.
- Proper access panels shall be provided for all the equipment and valves located above false ceiling.

## **3.0 FITOUT PROCESS**

### **3.1 PROCESS**

The Tenant is required to follow the below steps of

the Fitout process, after the granting of the Lease for a smooth transformation and safe occupation of the Premises.

#### **3.1.1 PRELIMINARY PLANNING**

The following process is to be followed:

- Obtain the Fitout Pack containing the Manual, as-built drawings, regulatory Authority guidelines and the Premises information from CPT.
- Pay the Fitout fees & security deposit
- The Tenant shall appoint Fitout Contractor for the design and execution of the Works. The Tenant shall ensure all specialist subcontractors, whether appointed by the main contractor or by the Tenant, shall be under the umbrella of the main contractor. The Fitout Team will not deal with anyone other than the main contractor appointed site representative.
- Arrange for an initial kickoff meeting with the FDM / Landlord in order to understand the processes and procedures.

#### **3.1.2 DESIGN SUBMISSION & APPROVAL**

The following process is to be followed:

- The Tenant's Contractor to submit the final proposal with all relevant documents
- Follow up with the relevant Tenant's Contractor for approval status of design submission through the FDM.
- Collect the Fitout approved drawings and NOC

- A copy of the approved drawings to be handed over to the FDM and a copy to be kept at the Premises.
- Proceed with Authorities approvals.

### 3.2 FIT-OUT PROCESS DETAILS

The Tenant is required to follow below steps:

#### 3.2.1 DETAIL PLANNING

The Tenant shall firstly obtain a copy of the relevant guidelines and as-built drawings for designing the Fitout for the Premises. These will be provided digitally as part of the Fitout Pack which has to be collected from CPT Management Office by producing a copy of the Lease. The Fitout Pack contains the following:

- Retail Manual (this document)
- CPT Fitout Forms
- DDA Fitout Guidelines & Procedures
- Premises Information
- Architectural / Structural As-built Drawings
- MEP Building Services As-built Drawings and Lease Owner Drawings
- HSE Procedure & Forms
- BTU Meter Guidelines
- DDA & DIFC requirements
- Handover Document Index Checklist
- Other relevant information

The Premises Information contains specific information in relation to the Premises. The Tenant must understand

the details of the Premises as set out in the Premises Information in advance for smooth and effective Fitout Works management.

To assist the Tenant to achieve the fitout objectives, it is recommended that the Tenant appoint experienced Contractors who will assist in the design, submission and approval stages as well as in project supervision and in order to achieve successful completion in accordance with the Landlord's requirements. It should be specifically noted that the appointed Fitout Contractor must be in possession of valid DDA accreditation without which DIFC will not issue their NOC.

#### 3.2.2 FITOUT COORDINATION FEES & SECURITY DEPOSIT

The Tenant is required to pay the Fitout fees to the Landlord. The fees are calculated upon both the type of Fitout and area impacted. In order to enforce the Fitout rules and to recover any cost of damage to common property, undated security cheque must be deposited by the Fitout Contractor.

The amount of the Fitout fees and security deposit is detailed as follow:

- The Fitout fee is AED 20,000/- or AED 5/- per sq ft + VAT whichever is greater payable by cheque or bank transfer in favour of the Landlord.
- Security deposit amount of AED 50,000.00 for areas

equal or less than 10,000 sq ft or an amount of AED 100,000.00 for areas more than 10,000 sq ft payable by undated cheque in favour of the Landlord.

The security deposit can be reclaimed by the Tenant contractor upon the conclusion of the Defects Liability Period provided that any defects and / or damages identified during the construction phase and / or Defects Liability Period have been rectified.

#### 3.2.3 LIMITING CONDITIONS

Please note the following conditions for the Fitout design and approval:

- Final approval is given for design intent only. It shall be the Tenant's responsibility to ensure that the Works are conducted in accordance with the requirements of all Authorities, in compliance with all laws, and in accordance with international best practice.
- The Landlord will not be responsible for any extension to the rent free period (if applicable) in the event that the Premises are not handed over to the Tenant within such period granted to him under the Lease due to delay in design submission, resubmission, execution and handover of the Works by the Tenant or the Tenant's Contractors.

### **3.2.4 DESIGN SUBMISSION & APPROVAL PROCEDURE**

The Tenant shall ensure that the design and installation Works is compliant with relevant laws, codes and the requirements set out in this Manual. The design submission and approval process for retail Fitout Works is illustrated below. In addition, the Tenant must submit the following to the FDM for approval:

- Details of the Tenant's Contractors, who is responsible for the design, overseeing and carrying out of each part of the Works
- Tenant's Contractors must first be approved by the FDM / Landlord and by DEWA for any MEP works as part of the Fitout Works
- Proposals for the daily liaison and co-ordination between the FDM and the Tenant's Contractors including the name of the individual who will have responsibility on behalf of the Tenant
- Method statement for minimizing any disturbance to the other tenants, owners or occupiers of any Premises near or adjoining to the Premises
- Any other matters the FDM reasonably requires
- Brand signage shall be installed in line with the Landlord and DIFC guidelines as per section 2.2.3
- Please refer to attached Process Flow Chart (see at end of this Manual) reflecting the days for each activity from getting Fitout pack until completion and obtaining DCD and DDA certificates.

### **3.3 FITOUT EXECUTION PROCEDURE**

#### **3.3.1 WORK FLOW**

The Works shall be carried out in accordance with the final drawings and conditions approved by the FDM / CPT / Landlord in accordance with this Manual. The items in the following sections illustrate the basic requirements to be followed by the Tenant and the Tenant's Contractors during the Works execution. Any deviation from the approved drawings and conditions not expressly approved by the Landlord shall be considered a defect and must be rectified at the Tenant's cost. A full set of the approved drawings and permits must be displayed within the Premises at all times during the execution of the Works for reference.

The Landlord / FDM will conduct routine site visits to the Premises and issue instructions / comments on the activities where appropriate and inform the Tenant's Contractor's site supervisor and the Tenant of any irregularities which could cause major delays or safety concerns, and the Tenant must immediately rectify such irregularities.

The Tenant's Contractor is responsible to provide necessary access above ceiling and under floor. In order to enable the Building facilities to be effectively coordinated and controlled, the Tenant is required to use Landlord approved Contractors for alterations to some critical common systems as directed by the Landlord.



The Tenant must comply with the Landlord's requirements in respect to site access, barriers for the Premises, bringing in and out of materials and equipment, site safety and cleaning of debris.

### 3.3.2 WORKS EXECUTION

Tenant's Contractor to coordinate with FDM to complete the relevant formalities on site such as:

- Permits to Work (PTW) and Tenant's Contractor access passes
- Site condition survey, snagging of the premises and handover of the keys. Followed by submission of dilapidation report as per CPT format.
- Temporary protection to floors / walls and for all live equipment devices, if any
- Installation of temporary DB with digital meter.
- Industrial sockets of 110 volts and 220 volts are only allowed.
- Mobilization of the Fitout Team and start the Works in accordance with approved drawings
- Appoint a full time supervisor at the Premises during the Works to attend to routine inspections by the FDM.
- The Contractor is obligated to submit an Inspection Check List of major installations of interface between existing and newly installed equipment and / or services for the FDM to verify and approve.
- Method statement for proper construction, delivery of materials and waste disposal to be submitted.
- Light pollution from construction activity must be

minimized by ensuring that light sources are controlled. Lux levels should meet DM code of construction practice.

The FDM or a member of his team may perform unscheduled observations / inspections to ensure scope is not exceeded and HSE measures are adequate.

### 3.3.3 PERMIT WORKS & PASSES

Once the final designs have been approved, FDM will issue an acknowledgement of site rules, a Permit to Work (PTW) and access passes. The PTW does not relieve the Tenant or the Tenant's Contractors from their obligations related to Civil and MEP design of the Works. The Tenant shall apply for special permits such as hot work, working at heights, lockout / tagout, etc. prior to carrying out such works. Contractors are

required to submit the permits 48 hrs prior to work commencement. The Tenant's Contractor can mobilize and commence their Works once the PTW and access passes have been issued. The passes shall be collected from CPT Security. No work or installation is allowed to proceed while the PTW is pending approval.

Should the Tenant or the Tenant's Contractors ignore this requirement, FDM / Landlord reserves the right to request the Tenant to replace the Tenant's Contractors or cut off electricity supply to the Premises, or any

other penalty or restriction that may be imposed, until such time as the FDM / Landlord is satisfied that the Tenant or the Tenant's Contractors (as the case may be) have complied with this requirement.

The image shows a 'PERMIT TO WORK-GENERAL' form from Central Park Towers. The form is divided into several sections:

- 1. General Details:** Includes fields for Permit No., Name of Permit Holder, Designation, Name of Contractor, Contact Person, and Contact Number. It also has a section for 'Details of Work To be Carried Out'.
- 2. Precautionary Measures:** A table with columns for 'Y', 'N', and 'NA' for various safety checks. Items include:
  - Risk Assessment
  - Method Statement
  - MDS for hazardous chemicals
  - Staff trained/competent to do the work
  - Site induction & briefing of PTW
  - Tools checked and safe for use
  - Scaffolding safe for use
  - Hoist Work
  - Electricity isolated
  - Electrical switches locked-out
  - Valves locked-out
  - Warning leg/holse and barricades
  - Ventilation and lighting are adequate
  - Site inspected and free from known hazards
  - SMU safe for use
  - (If Attached) SMU checked
- Additional measures implemented to ensure the work can be carried out safely:** A text box for notes.
- Personal Protective Equipment (PPE):** A row of icons for various PPE items: Hard hat, Safety glasses, Goggles, Earplugs, Earbuds, Ear muffs, Coveralls, Dust mask, Respirator, Gloves, Fall harness, and Hi-visibility vest.
- Additional PPE to be used:** A text box for specifying extra PPE.
- Contractor Acknowledgment:** A section where the Contractor Representative acknowledges the above and agrees to:
  - Have briefed all its employees and sub-contractors on relevant guidelines and procedures.
  - Understand and agree to Central Park Towers Health & Safety Guidelines.
  - Understand and agree to Central Park Towers Health Waste Management & Recycling Guidelines.
  - Understand and agree to Central Park Towers Emergency Evacuation Plan.
  - Have all relevant PPE and tools available to conduct work safely.
  - Be fully responsible for all employees and sub-contractors on site.
  - Shall indemnify and hold harmless Central Park Towers / Arady Developments LLC for any occurrence.
  - Maintains adequate insurance for damage to premises, equipment, and third-party liability.

At the bottom, it says 'CPT-FRMA-PTW-R02', 'Page 1 of 2', and 'Date: 01-01-2021'.

### 3.3.4 PERMIT TO WORK REQUEST

The following documents and drawings are to be submitted to the FDM for review and final approval along with the PTW:

- Appointment Letter for the Tenant's Fitout Contractors by Tenant

- Copy of valid Commercial License and Tenant Lease issued by DIFC
- Copy of valid professional Trade License of all Tenant's Contractors
- Workman's Compensation Insurance Policy
- Public liability insurance / Third party insurance
- NOCs from Authorities as specified by the Landlord
- DM and / or Environment Authority approval for kitchens
- Outline program of Works
- Copies of fees and security deposit receipts (as per clause 3.2.2)

Contractor to proceed with submission of above documents to DIFC in order to obtain their Fitout NOC.

Thereafter they need to proceed with Authorities such as DCD, DDA, DEWA & DM food control / DHA as applicable. DDA night shift permit to be obtained in case night works is proposed.

### **DRAWINGS**

All the relevant drawings and layouts applicable for the Works from the below list shall be submitted in A2 & A3 size hard copy (1 set each) and DWG & PDF format soft copy for review and update.

- Existing as-built drawings
- Existing DEWA approved load schedules & single line diagrams
- Plans, elevation, sections (scale 1:50 or larger to fit A2 size sheet), internal views

- Detail or enlarged layouts
- Layouts indicating corridor width, height etc, if any
- CCTV drawings
- Fire & Life Safety schemes
- Proposed Architectural layout
- Proposed Structural layouts, if applicable
- Coordinated reflected ceiling plan with final MEP fixtures
- Proposed coordinated MEP services layouts
- HVAC layout
- Water supply layout
- Mechanical equipment schedule
- Heat load calculations
- Power Layout Indicating Meter Location
- Power distribution layouts
- Lighting distribution layouts
- Load schedules
- Single line schematic diagrams
- Fire detection & protection layouts (fire fighting & fire alarm systems)
- Emergency battery system layouts (standalone)
- Drainage layout
- Data point cabling drawings
- BTU meter installation details
- Gas layout (if applicable)

### **3.3.5 PREMISES ACCESS**

All employees of the Tenant and the Tenant's Contractors (Site Employees) are required to carry

a valid access pass in order to be able to enter the Premises for security reasons. It is the Tenant's sole responsibility to ensure that the Tenant's Contractors fully understand the Rules and Regulations and sign the Terms and Conditions prior to the commencement of any work on site.

### **3.3.6 PRECAUTIONARY MEASURES**

The Tenant's Contractors are required to protect all existing equipment and fire alarm and other devices temporarily using suitable covers before starting any works at the Premises to avoid activation due to construction dust. Additionally the Tenant must ensure that all Works will in no way affect the functioning or efficiency of existing fire protection systems and means of escape. Any work that may generate sparks, open flame or create high temperatures requires FDM / Landlord prior written approval, which will be subject to the condition that all fire safety requirements have been met including hot work permit.

### **3.3.7 INSPECTION OF WORKS**

During the Fitout works and after completion of each stage of Fitout, the Contractor must take the approval from the FDM for all MEP works before connecting to the main Building services as per the following inspections list:

- Installation of setting out of partitions

- Inspection of surface preparation for water proofing
  - Inspection of water proofing application to wet areas
  - Inspection of flood test after 48hrs of water ponding
  - Installation of fire rated walls
  - Inspection of fire suppression system for kitchen
  - Inspection of the installation for fire fighting network
  - Inspection of fire fighting pressure test
  - Inspection of AC and fresh air ducting
  - Inspection of the installation of chilled water network and flushing
  - Inspection of chilled water network pressure test
  - Inspection of the installation and pressure test of water supply network
  - Inspection of the installation and pressure test of drainage network
  - Inspection of fire alarm and emergency battery system
  - Inspection of cable termination to main DB
  - Inspection of MEP works prior to closing of ceiling
- Refer to Fitout pack for the full comprehensive list of inspections

### 3.3.8 TESTING & COMMISSIONING

The TAB of all the MEP services especially HVAC installation, fire fighting and fire alarm installation for major Fitout must be carried out by a Landlord approved third party Contractor and must be witnessed by the FDM.

Flushing of CHW system shall be carried out with a DM approved laboratory. The water during flushing process shall under no circumstances be discharged into the Building drainage system as per DM regulation. The Contractor shall make their own arrangements to dispose the flushing water outside to DM dedicated waste disposal site or shall arrange to neutralize the contaminated water to pH levels in compliance with DM standards.

All commissioning and balancing reports should be submitted to the FDM for final inspection. For minor Fitout Works, the testing and balancing may be carried out by the Tenant's Contractor in coordination with the FDM / Landlord.

### 3.3.9 LABELLING OF EQUIPMENT

Any and all additional equipment, cabling and pipe work must be labelled in accordance with original standards and specifications and identified on as built drawings. DB, FACP & Access Panels to be labelled



## 3.4 WORK COMPLETION & OCCUPANCY

### 3.4.1 FINAL INSPECTION

Upon completion of the Works, the Tenant shall notify the FDM by submitting a Fitout Completion Inspection Request along with the Tenant's acceptance letter for completion and commissioning reports for MEP services. A joint inspection with the Landlord will then be conducted on a mutually agreed date and time with the Tenant and the Tenant's Contractor.

Based on final inspection, the Landlord will either:

- Issue a move-in NOC; or
- Not issue the NOC, and provide a detailed list of Work required to be completed in order for that certificate to be issued

If a move-in NOC is not issued, then on receipt of the reasons, the Tenant must carry out the Work referred to in that list and, on completion of that Work, re-submit a Fitout Completion Inspection Request and the above procedure shall again apply.

The applications for utilities such as electricity, telephone, water and CHW to relevant utility companies / government departments are the responsibility of the Tenant and should be submitted well in advance. Upon satisfactory completion of all Works the Tenant or their nominated contractor shall provide the FDM copies of the following documentation:

- Completion Certificates from relevant Authorities
- Copies of all Certificates of Compliance from relevant Authorities
- Copies of Certificate of Compliance from contractors stating that all works undertaken comply with relevant laws, regulations and standards
- Drawings

On completion of the Works, the as-built drawings shall be provided. One set of A1 prints, one set of A3 prints and soft copy files in CAD & PDF format on USB are required. Wherever possible, these should be "Full Floor" drawings. Services consultants should check with the FDM to see if CAD files for any adjoining tenancies are available. If they are available, then combined drawings are required.

These drawings shall include, but not be limited to:

- Floor Plans – including partition layouts, baffles location work stations and to clearly display any alterations to Building finishes
- Reflected Ceiling Plans
- Fire Sprinkler and Smoke Detectors – including detailed legends
- Electrical Layouts – including detailed legends and independent test report
- Electrical Wiring Diagrams – including detailed legends and independent test report
- Air Conditioning Layouts – including detailed legends and clearly nominating blanked off duct outlets not required, all balance data and heat load

calculations (together with equipment layout, air and water flow rates)

- Lighting Layouts and Emergency Lights – including detailed legends
- Hydraulics – including detailed legends and clearance certificate

All drawings submitted shall be prepared to acceptable industry standards.

### 3.4.2 TESTING & COMMISSIONING DATA



A full set of signed commission test results for relevant Building services shall be submitted to the FDM.

The as-built drawings of the Premises will be stored in the database and updated in the base Building layouts by the FDM and made available for future use. The Tenant acknowledges that the Landlord will have the right, notwithstanding the expiry or earlier determination of the Lease, to use the drawings in

any manner for whatever purpose the Landlord deems fit. The Premises cannot be occupied unless the Fitout Completion Certificate has been issued by DDA and Move-in NOC by the Landlord.

### **3.4.3 DEFECTS LIABILITY MANAGEMENT**

During the defects liability period, being 365 calendar days from the issuance of the Fitout Completion Certificate, the Tenant shall attend to and rectify any defects in the Works including any operational or indoor environment issues caused by any of the system modification and / or fit-out activities at the Premises.

### **3.4.4 HANDOVER OF LEASED PREMISES**

The FDM and the Landlord will conduct a joint inspection of the Tenant's leased Premises and any defects (excluding defects in the Works, which shall be addressed under the Defects Liability Management) will be recorded using Leased Premises Handover Checklist.

### **3.4.5 HANDOVER DOCUMENTS**

Submit handover documents such as as-built drawings of all disciplines, operations & maintenance manuals, warranty certificates, testing & commissioning documents certified by third party agency, etc, as per

the check list provided with the Fitout Pack.

The above steps of the Fitout process, followed by the defects liability management, are illustrated in detail in the respective sub-sections below.

### **3.4.6 TAKEOVER OF VACATED PREMISES**

Upon notification from the Tenant, the FDM and / or the CPT representative will conduct an inspection to assess the condition of the Premises using the Leased Premises Handover Checklist as a base. The Tenant obligation is to reinstate the Premise to its original status prior to Fitout.

### **3.4.7 LIABILITY**

The Tenant's duties, obligations and responsibilities to the Landlord under and in connection with the Lease and the Fitout Pack including but not limited to this Manual. The Tenant's liability to the Landlord for the consequences of any breach of the Lease and the provisions of the Fitout Pack (including but not limited to this Manual), negligence or other default shall in no way be excused, waived, negated or diminished by:

a) Any process of review, checking, inspection, examination, testing, monitoring and / or supervision which may be carried out by the FDM, or their affiliates or other consultants or any other persons appointed or authorized by the Landlord.

b) Any acknowledgement, approval or consent, or any comment, proposal, request, notice, instruction or certificate which might be made, given or issued by the Landlord during the carrying out and / or as a consequence of the tasks leave in or on the recommendation or advice of the Lessee.

The Tenant shall not be excused from performing his duties and / or obligations under the Lease and the Fitout Pack (including but not limited to this Manual), and its liability for any act, omission, breach, negligence or other default shall not be waived, negated or diminished in anyway, Any failure on the part of any of the Landlord's Parties to carry out and / or complete any of the tasks referred to in paragraphs (a) and (b) above either properly or at all or as a consequence of any failure to discourage, withhold approval or consent to or object to whatever may be proposed or done by the Tenant.

### **3.4.8 INDEMNITIES**

The Tenant shall indemnify the FDM unconditionally and irrevocably and agrees to keep the Landlord so indemnified against all actions, suits, proceedings, claims, costs and demands it or any other person(s) now or anytime thereafter may have against the Landlord relating to any act, omission or negligence of the Tenant or its Contractors in carrying out any proposed works.

## **4.0 FITOUT RULES & REGULATIONS**

### **4.1 INSURANCE & LICENSES**

The Fitout is to be undertaken in accordance with the provisions and responsibilities set out by relevant Authorities, as outlined in this Manual and the general rules and regulations for the Works in terms of health and safety of the Premises and the occupants set by the Landlord illustrating various aspects to be followed by the Tenant and the Tenant's Contractors during the Works execution at the Premises to avoid health, safety and environment issues.

- All Contractors / Consultants are required to arrange and keep current the following insurances:
- Workmen's Compensation Insurance
- Public Risk / Third Party Insurance (minimum of AED 3 Million)
- Professional Indemnity (where applicable)
- Contractors All-Risk Insurance
- Motor Vehicle Liability Insurance
- All relevant licenses applicable to trades i.e. Fitout / Builders License, Electrical License, etc.

### **4.2 WORKING HOURS**

The Works are to be timed according to normal business hours of 08:00 hrs to 18:00 hrs Saturday to Thursdays. If the Works do generate noise and / or disturb others, then the Tenant may seek FDM written

approval to conduct the Works outside of these working hours subject to obtaining approvals.

### **4.3 BREACH OF RULES**

If the Tenant or the Tenant's Contractor contravenes any rules or regulations contained within this Manual including health and safety requirements, activation or modification of fire alarm systems, floor boxes relocation (power and data) and fire fighting shutoff leading to draining of pipes not duly approved, or ignores FDM instructions or fails to adhere to acceptable working practices, Tenant may be penalized and have fit-out works suspend at any time. Where the breach of rules impacts the safety or privacy of the Premises by others, then the FDM at his discretion may insist that its representative is engaged on a full time basis to oversee the Works. The cost of this resource(s) shall be borne by the Tenant. Should this action prove necessary, notice will be given to the Tenant in writing and FDM shall not be responsible for claims of any nature arising from the action.

### **4.4 CONTRACTOR'S CONDUCT**

The Tenant shall ensure the Tenant's Contractors follow, and ensure that the Site Employees abide by, the following conduct during the Works at the Premises. Eye, ear and respiratory protection must be worn when the task requires.

- Hard hat, safety footwear and uniform / coverall must be worn at all times
- Gloves must be worn where there is a risk of cuts and abrasions to hands
- Know the emergency procedures and where the assembly points are
- All injuries, however trivial, must be reported to the CPT security / FDM and recorded in the Site Accident Book. Diabetics, asthmatics, epilepsy sufferers and persons using drugs for medication are required to report their conditions to their managers to allow suitable work to be allocated. This information will be treated confidentially.
- Alcohol, drug and solvent abuse is not permitted on site at any time. Anyone suspected of being under the influence of alcohol / drugs / solvents whilst attempting to enter the site will be refused entry. Anyone found on site under the influence of alcohol / drugs / solvents will be liable to disciplinary action, which will involve removal from site.
- Smoking on site is strictly prohibited
- Cooking on site is strictly prohibited
- There will be no sleeping allowed at the Premises
- A waste recycling scheme is operated wherein waste is to be segregated into separate skips. This waste management system is mandatory and any company or person found abusing the system is liable to disciplinary action.
- Radios, headphones personal stereos etc. are not

permitted on site

- Keep your workplace tidy, clean and do not leave material or equipment where people can trip
- The use of cartridge tools is not permitted

#### 4.5 PROTECTION MEASURES

During the tenancy Fitout Works, the Tenant is required to protect the common area floors and walls leading to the Premises. Floors are to be protected with 2000 gage polythene sheet & plywood. Walls, doors and door frames are to be protected with Corflute / Corex sheet. Similarly, service lifts floors are to be protected with Corflute / Corex sheet and walls are to be protected with Corflute / Corex sheet.



Curtain walls (where applicable) should be protected during the Works period to minimize the risk of damage to the glass, its coating and to the sills and mullions. Any temporary or permanent fasteners will

not be permitted. The Tenant is responsible for any damage caused to the fixtures and finishes in the common areas that arise due to the Works.

#### 4.6 DUST & NOISE EMISSIONS

In order to avoid nuisance to other occupants, the doors of the Premises must be kept closed at all times while the Works are in progress. All glass partitions and doors separating the Premises from public spaces must be neatly covered on the Tenant's side with a white opaque material such as paper or wall covering. Dust and odors created by the Works must be contained within the Premises. Noisy / dusty works and wet operations shall be controlled as per Landlords standards.

Noisy works should comply with DM noise criteria during works and follow as per PTW requirements.

#### 4.7 TEMPORARY HOARDING SPECIFICATION

In consideration of the safety of other Building occupants, staff and general public, the Tenant shall ensure that the Tenant's Contractor does not completely block access routes while work is being done on Premises. The Tenant shall maintain adequate entry and exit routes at all times. After receiving formal written approval from FDM, the Tenant shall erect a temporary hoarding as a protective measure and to maintain adequate entry

and exit to the Building and its facilities.

The Tenant's Contractor is not to store any materials, rubbish, equipment or other items in the fire stairs nor block off any access or egress from any fire stairs or fire doors.



The Premises shall be enclosed within the hoardings constructed from 19mm plywood sheets 1200x2400 on 60x60 softwood frames bolted together. The hoarding shall contain a single entrance lockable from inside and outside and shall be kept secured at all times. A spare set of keys must be given to the FDM for emergency access to the Premises.

Where applicable, a hoarding shall be erected on the

Premises boundary as shown on the Lease outline drawings and shall not be removed, extended or dismantled without prior written permission from FDM. Hoarding may be moved into the common area (to a limited extent only) to permit the execution of the Tenant's signage and shop front works, and only after formal written permission from FDM.

During the construction period, all Tenants will be required to provide and maintain clear copy of PTW & DDA permit (A4 size) on the tenancy door or hoarding to indicate the Works permits provided by the Landlord.

#### **4.8 VEHICLE ACCESS & MATERIAL DELIVERY**

All materials and debris are to be transported to and from the Premises using the designated GF Loading Bays and / or designated car park bays. All material deliveries to the site will be deposited at a single drop off point as indicated by the FDM. The items are to be taken immediately to the Premises. Prior arrangement must be made for the delivery of heavy equipment due to load capacity considerations.

At least two working days' advance notification for arrangement of such deliveries is required. The Tenant shall provide the size and weight of the heavy equipment when making such a request.

If the Tenant's Contractor is planning to remove large volume of materials / goods from the site, the tenant

should complete the Exit Permit Form and submit it to the FDM for approval at least 24 hours prior to departure time. This form must be endorsed by the Tenant and validated by the FDM and will facilitate security clearance, otherwise no one will be allowed to take any material or equipment off the Premises.

#### **DELIVERIES & LOADING BAY**

There is a delivery area and a Loading Bay located in the Building and Tenants and Contractors are expected to utilize this area for all deliveries. Ensure that height of delivery items do not exceed 2400mm at Loading Bay. Load carrying capacity of trucks not to exceed 5 ton total load. The Tenant is expected to liaise with the FDM prior to arranging deliveries.

#### **4.9 STORAGE & HANDLING OF MATERIALS**

All equipment, tools and materials brought onto the Premises are the Tenant's sole responsibility and must be stored within the Premises at all times. There is no storage area available on site outside the working area and the Tenant shall ensure that the Tenant's Contractor bring materials to site on a day to day basis. All loose materials including cement, screed, and plaster must be delivered to the Premises bagged. Storage and mixing of materials must occur within the Premises, except by prior arrangement with FDM. All floors, lifts and staircases must be



protected to prevent damage and the possible seeping of materials into other areas outside the Premises. The movement of materials between floors, use of staircases along with the use of the designated lift shall be controlled to specific timing and prior permission has to be obtained in writing. Fire hazard materials and chemicals to be stored at dedicated space and properly segregated away from works.

#### **4.10 WASTE DISPOSAL & DEBRIS REMOVAL**

The Contractor shall demonstrate and implement a waste management plan according to ASTM E 1609 and other sustainability requirements. Plan shall consist of, but not limited to, waste identification, waste reduction work plan, and cost / revenue analysis. Also, indicate quantities by weight or volume, but use same units of measure throughout waste management plan. No accumulation of waste will be tolerated inside or outside of the Premises. All waste disposals units must be regularly emptied so that there is no overflow of waste materials. Large volume debris removal will be at the Tenant's expense. Any abuse of the debris removal volume by the Tenant and the Tenant's Contractor will result in additional costs being assessed by the FDM and payable by the Tenant. Waste management policy

adopted by CPT should be implemented by the Contractor.

Recyclable paper, plastic and cardboard shall be disposed by the Fitout Contractor into CPT recycling center located on B4 Level.

Demolition and construction waste going in landfill and also recyclable to be segregated.

At least fifty percent (50%) by volume or weight of waste material generated during the construction and or demolition of Buildings must be diverted from disposal in landfills. Diverted materials must be recycled or reused.



#### **4.11 WET AREA WORKS**

Where the Tenant's contractor carries out work involving wet trades, a suitable waterproof membrane must be laid to ensure that moisture does not penetrate to other work areas. Proposed materials and method statement must be submitted to the FDM for written approval.

In case the Tenant wishes to construct a wet

area within the Leased Premises, the following requirements must be adhered to and shall form part of the design submission for the Works:

- Walls shall be constructed from 100mm thick hollow block or moisture resistant gypsum / calcium silicate board only
- Waterproofing must be done if required by the FDM
- Waterproofing works shall be carried out by specialist applicator engaged by the Contractor approved in writing by the FDM and a five (5) year minimum guarantee shall be submitted against workmanship and material
- No penetration is allowed through floor slabs

#### **4.12 GENERAL WORKS**

All construction activities must be contained within the Leased Premises. The Tenant's Fitout Contractor is responsible for ensuring compliance with DDA, HSE and Insurance requirements. The Premises are expected to be kept clean, organized with materials neatly stacked and safe at all times during the Works. To avoid any Fitout debris / dust entering the air-conditioning equipment and adversely affecting its efficiency, air-conditioning system shall not be turned on while Works are in progress and all inlets and outlets must be properly sealed. Slabs, columns, walls and beams must not be drilled, cored, cut, chipped or chased under any circumstances. Anchors into slabs and beams such

as required for relocated sprinklers, ductwork, and suspended ceiling will be permitted but such anchors must be fully described in the drawings and specifications. It is prohibited to join ( under any circumstance) electrical wires or cables directly without using proper joint ferrules, PVC connectors or cable joints.

#### **4.13 TEMPORARY FIRE PROTECTION**

The Tenant must ensure that proper and adequate fire fighting equipment (e.g. portable fire extinguishers, fire blankets and sand buckets, etc.) is made available at the Premises by the Tenant's Contractor. Extinguishers must be in current service and in working order.

A minimum of one CO2 hand-held extinguisher (min. capacity 4.5 kg or 10lb) shall be provided for every 1,000 sq. ft. of leased area. Where there is smoke or dust arising from construction or debris removal, the Tenant shall request to FDM to isolate smoke detectors located on that floor to prevent false fire alarms during such works.

Sprinklers and fire alarm shutdown / isolation works can only be done by the Landlord approved contractor at the Tenant's expense, after approval has been granted in writing by FDM. A fire watch should be maintained throughout the period of sprinklers and / or fire alarm isolation and especially during hot Works.

Fire watch shall either be provided by the Contractor or by the Landlord's Contractor (at Tenant expense at the discretion of FDM,) if it is demonstrated that sufficient procedures have been established.



#### **4.14 TEMPORARY ELECTRICAL & WATER SUPPLY**

The FDM will designate power points where the Tenant's Contractor can obtain electrical supply for its temporary DB. The DB shall have sufficient number of industrial sockets with 110 volts and one single industrial of 220 volts along with switch socket for charging electronic devices only.

The customary provision is 50 VA/m<sup>2</sup>. The Tenant shall coordinate with the FDM to wire their equipment from a designated electricity supply board and be responsible for earthing wires, over current and earth leakage protection and whenever additional three-phase power is required.

Any specialist power requirements by the Tenant's Contractor must be brought to the attention of the

FDM prior to commencement of work. The FDM may request the Tenant to provide a calibrated electricity meter be fitted to the temporary DB and paid monthly in arrears.



The FDM reserves the right to withdraw power supply unconditionally in the event of evident misuse of energy (e.g. unauthorized connection, extra load added without prior information and approval). FDM shall not be liable in any manner whatsoever for any consequences arising out of the Tenant's use of electrical energy. The Tenant shall be fully responsible for the safe operation and security of the installations and the safety of Site Personnel. FDM will designate wet points where the Tenant's Contractor can obtain water for the works, if required. The Tenant will be solely responsible for ensuring that

the Tenant's Contractor collects, transports and uses water in a safe, clean and professional manner. The Tenant will be responsible for the cost of connecting with the supply valve to CPT water meter designated by the FDM for all supply lines from thereon. The Tenant will also be responsible for coordination for the connection to the BMS (where available). Important Note: Under no circumstances are the hose reels or other parts of the fire prevention system to be used as a source of water. For Tenants not installing wet pantries or internal plumbing works, the Tenant must contact the FDM for access to other sources of water within their Premises, if required.

#### 4.15 INDOOR AIR QUALITY

##### 4.15.1 VENTILATION REQUIREMENTS

Premises must be mechanically or mixed mode ventilated and must comply with the minimum requirements of ASHRAE Standard 62-2007. Occupancy density for each space is determined based on its activity in accordance with the requirements of DM if available or using the default occupancy density values in ASHRAE 62-2007. In CPT, The occupancy rate shall be in compliance with maximum occupancy load factor as per Authority regulations.  
Office Tower = 9.3 m<sup>2</sup> / person  
Retail = 2.8 m<sup>2</sup> / person

##### 4.15.2 AIR QUALITY DURING FITOUT

Building occupant and systems must be protected from airborne contaminants which are generated or spread during construction or renovation. HVAC system openings must be closed and protected from contamination. All duct and other related air distribution component openings must be covered with tape, plastic, sheet metal or other methods to prevent dust or debris from collecting in the system. If the HVAC system is used during construction or renovation, temporary return air filters must be installed with a Minimum Efficiency Reporting Value (MERV) in accordance with ASHRAE Standard 52.2-2007 or an equivalent standard.

#### 5.0 GENERAL REQUIREMENTS

##### 5.1 ADHESIVES / GLUE & SEALANTS

For field applications that are inside, the weather proofing system, adhesives and sealants shall comply with the following VOC content limits when calculated according to EPA and local DM reference, which is rule EPA Chapter 159. Control of VOC from adhesives and sealant shall be followed by Fitout Contractor. Furthermore, according to DM Green Regulation Section 404.02, every Fitout Contractor using adhesives, adhesive bonding primers, adhesive primers, sealants and sealant primers inside the Building shall not exceed allowed limits of VOC.

These materials must be certified from a DM approved Laboratory. For any Fitout space, where activities produce hazardous fumes or chemicals, space must be provided with separate air extraction systems to create negative pressure and exhaust the fumes or chemicals to ensure they do not enter adjacent offices / units.

Dangerous goods must be stored in accordance with DM requirements.

Note: As a general requirement, any chemical or material that may likely cause harm to people or ability to impose health risk to workers and property has to be avoided and further ensure all chemicals are human friendly and use in accordance with local DM requirements.

PRODUCT TYPE	Maximum grams of VOC per liter of adhesive or sealant, less water and exempt compounds
Indoor Carpet Adhesive	50
Carpet Pad Adhesive	50
Wood flooring Adhesive	100
Rubber flooring Adhesive	60
Sub-floor adhesive	50
Ceramic tile adhesive	65
Cove base adhesive	50
Plaster board and wall panel adhesive	50
Multipurpose construction adhesive	70
Structural glazing adhesive	100
Architectural sealants	250

## 5.2 PAINTS & COATINGS

For field applications that are inside the weather proofing system, paints and coatings system shall comply with EPA and local DM reference, which is rule EPA Chapter 159. The products shall have following VOC content limits when calculated according to the above table. These materials must be accredited / certified from DM approved Laboratory.

Product Category	Type**	Phase II (g/l)*
Interior matt walls and ceilings (Gloss<25@60°)	WB SB	30 30
Interior matt walls and ceilings (Gloss>25@60°)	WB SB	100 100
Interior trim and cladding paints for wood and metal	WB SB	130 300
Interior trim varnishes and wood stains, including opaque wood stains	WB SB	130 400
Interior minimal build wood stains	WB SB	130 700
Primers	WB SB	30 350
Binding Primers	WB SB	30 750
One-pack performance coatings	WB SB	140 500
Two-pack reactive performance coatings for specific end use such as floors	WB SB	140 500
Multi-colored coating	WB SB	100 100
Decorative effect coatings	WB SB	200 200

\*g/l of ready to use product

\*\*WB=Water Based & SB=Solvent Based

## 5.3 CARPET FLOORING

Carpet flooring must meet or exceed one of the following standard requirements:

- Carpet and Rug Institute Green Label
- Green Label Plus Program
- Greengard Indoor Air Quality Certification Program For Carpets

## 5.4 CEILINGS

The selection of ceilings materials, tiles shall be to ensure the emissions for suspended ceiling system quality for indoor space shall comply with British Standard European Norm 13964:2014. In relation to asbestos-free products and formaldehyde content of materials, these shall meet Class E1 at a minimum and shall be tested, properly marked and classified accordingly.

## 5.5 ACOUSTIC COMFORT

CPT is complying with acoustic noise comfort levels. The acoustic performance relating to Internal noise criteria and noise sound pressure levels must meet the control requirements as per Building regulations approved document E (revised 2003) (UK) and Commercial Buildings BS8233:2014 Sound insulation and noise reduction for Buildings – code of practice. (UK)

Ablution Fixtures	1.9 l/min at 417.7 kPa	
Urinals	0.5 l/flush	Infrared sensors
F & B Dining Space		14.0

## 5.6 INTERIOR FINISHES

All interior finishes such as composite wood, agrifiber products, and furniture shall not contain or exceed minimum urea- formaldehyde resin VOC content Class E1 Levels.

## 5.7 LIGHTING FIXTURES

Lighting fixtures should be of the following power rating in the corresponding spaces.

No incandescent lighting fixtures should be installed and only high frequency electronic ballast should be installed that conforms to international standard approved by DEWA / DM.

Space Type	Lighting Power Density (W/m <sup>2</sup> )
Kitchen	13.0
Retail Area	18.1

## 5.8 WATER FLOW FIXTURES

The applicable water flow fixtures should be installed with the specified flow rates at the corresponding pressure shown in the following table.

Fixtures	Flow Rates	Automatic Control
Kitchen Taps	5.7 l/min at 417.7 kPa	
Bathroom Washbasin Taps	1.9 l/min at 417.7 kPa	Yes
Toilets, Dual Flush	6 l/flush (High) 3 l/flush (low)	

## 5.9 MATERIAL & RESOURCES

The insulation material must comply with DM requirements. High quality of appropriate density rock wool shall be used during the fit-out.

1. The insulation materials to be incorporated into the Premise must:

- Be manufactured without the use of Chlorofluorocarbons (CFC's)
  - Be non-toxic and not release toxic fumes during combustion
  - Have 0.05 parts per million (ppm) or less of added formaldehyde
  - Have a Threshold Limit Value (TLV) of 0.1 or less of individual VOC
  - Be fire resistant in accordance with the requirements of DCD
  - Be accredited / certified from DCL
  - Achieve all the requirements of the approved specifications by DM for thermal and acoustic criteria
  - All thermal and acoustical insulation must be installed as per the manufacturer's instructions after approval from DM
2. Timber and timber-based products installed in the Building must be from certified / accredited sources approved by DM.
3. Addition or alteration of existing Buildings materials containing asbestos must not be used.
4. Paints or other materials, containing lead or other heavy metals with percentage more than the

approved specifications by DM must not be used.

5. Composite wood products used in the interior of the Building must not contain added urea formaldehyde resins.

## 5.9 SMOKING CONTROL POLICY

Smoking is strictly prohibited inside CPT and also prohibited in external spaces of the plot boundary. There are designated smoking areas around the exterior of the Building.

## 6.0 HSE FORMS – As Per Appendix - 1 (Refer Fitout Pack)

## 7.0 DDA FITOUT GUIDELINE - As Per Appendix - 2 (Refer Fitout Pack)

## 8.0 FITOUT FORMS - As Per Appendix - 3 (Refer Fitout Pack)

## 9.0 BTU METERS INSTALLATION GUIDELINES - As Per Appendix - 4 (Refer Fitout Pack)

## 10.0 CHILLED WATER CONNECTIVITY, CONSUMPTION & ACCOUNT MANAGEMENT

## GENERAL REQUIREMENTS

Each unit is required to apply for a permanent chilled water connection via a metered service.

The application for the meter installation should be made as part of the overall Fitout application to the Landlord. Submissions that do not include the approved chilled water connection application form 'FMCWM001' will not be issued an NOC.

The Landlord has appointed a specialist Chilled Energy Service Provider, Logic Utilities District Cooling LLC (Logic Utilities) for procuring & installing the Tenant's BTU meter along with billing and collection services for consumption. The Tenant is responsible for registering with the service provider and paying their monthly cooled energy bill on time.

## METER INSTALLATION

Tenants will be required to order the BTU meter and valve kit should be installed within the unit demise. Retail Tenants must provide a dedicated ceiling access hatch 600 x 600 mm with clear access to the BTU meter and isolation valves. This should be located at the front or rear side (depending on the unit) of the retail space, where the current stub outs are installed. This should be shown on RCP as part of the design.

The Tenant shall liaise with Logic Utilities for procurement of meters and detailed installation information regarding the same. Logic Utilities

will provide supervision during the works and connectivity into the network.

## ACCOUNT MANAGEMENT

In addition to applying for the BTU meter and installation, the Tenant must have an activated account with the Landlords appointed chilled energy service provider, Logic Utilities. This will require registration to take place. Each Tenant will be required to sign Logic Utilities standard terms and conditions and pay the associated account activation fee and security deposit.

## ACTIVATION OF CHILLED ENERGY

The meter installation and activation of the supply may take up to 6 weeks. Therefore the Tenant is requested to take this into consideration when developing their fitout program.

The Landlord takes no responsibility in delays due to late applications or failure to provide adequate information during the account registration stage.

The Landlord, at his discretion, may allow for a temporary chilled water connection to be made to the Permisses. The temporary connection application can be made through the FDM.

## FEES & CHARGES

The following fees are applicable for Chilled Energy Services:

- BTU meter supply only, installation by others (retail) – AED 3,000.00
- Account activation fee - AED 500.00 payable once to open an account.

• Monthly invoicing and collections fee - AED 30.00  
The amount is added to the monthly invoice and is paid by the Tenant.

- Security deposit – AED 4,000.00 for retail units.  
The amount will be held in the case of non-payment of invoices. All security deposits are to be held by the service provider.

- Late payment fee - AED 50.00 applied to the account for payment received after the due date.
- Returned cheque fee - AED 500.00 applicable for the cheque payments that have been returned by the bank for any reason.

- Water meter supply - AED 1028.37
- Water meter installation charges - AED 750.00
- Reconnection fee - AED 1,000.00 payable to the service provider to reconnect the service after the disconnection due to non-payment.

Note: Logic Utilities reserves the right to vary the fees. All fees / deposit are exclusive of VAT.

## CONTACT DETAILS

Logic Utilities District Cooling LLC

Account Management

Email : meters@logicutilities.com

Call : 04 429 6082

( 9 AM TO 5 PM, Sunday through Thursday )

## 11.0 TIMELINE

Please refer to attached Process Flow Chart (next page) reflecting the days for each activity starting from obtaining Fitout Pack until obtaining DDA Completion Certificate.

## A - Summary of fitout procedures and timeline

## B - Design submission and approval

# FITOUT PROCESS FLOW CHART

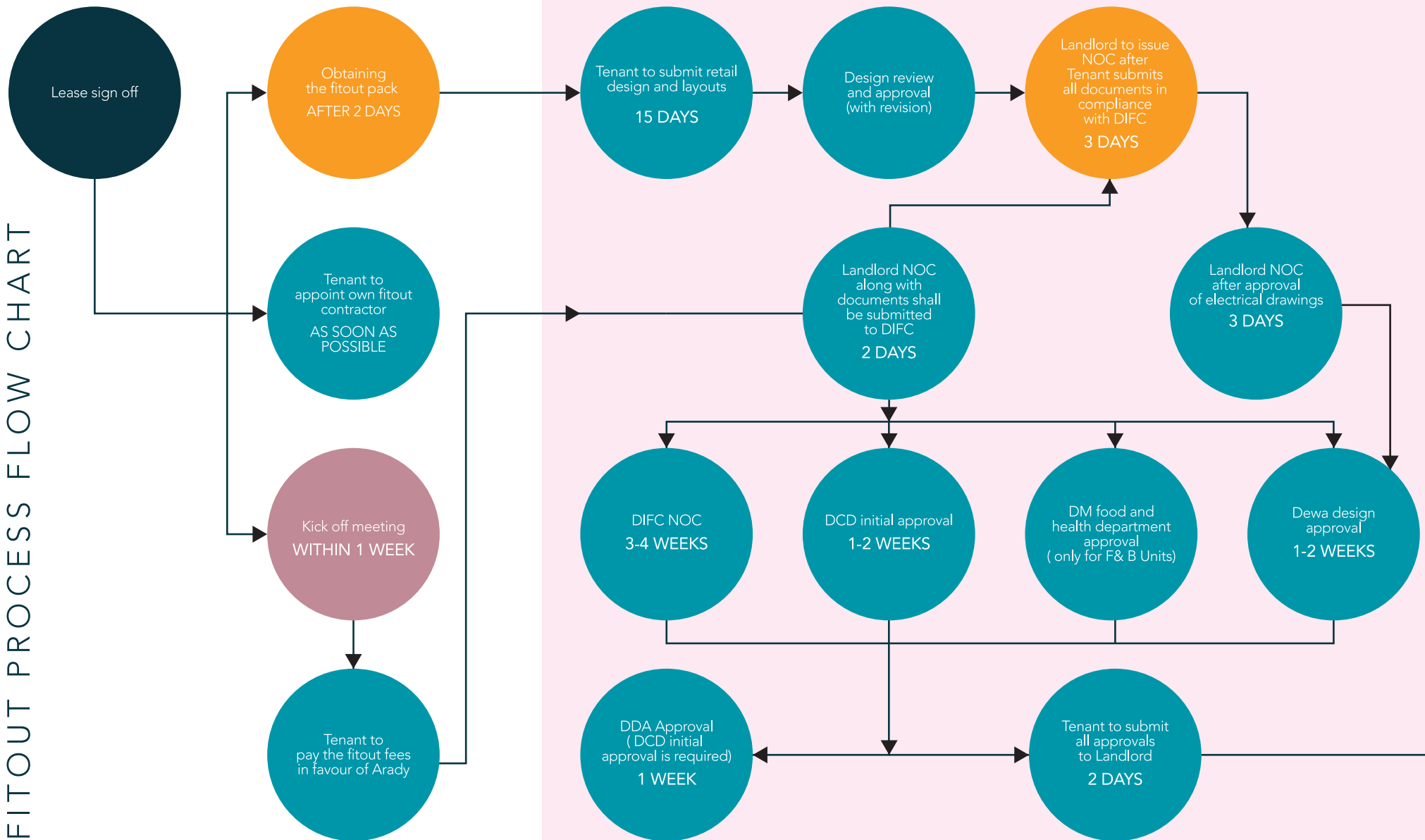



## C - Fitout Execution process

## D - Closing process

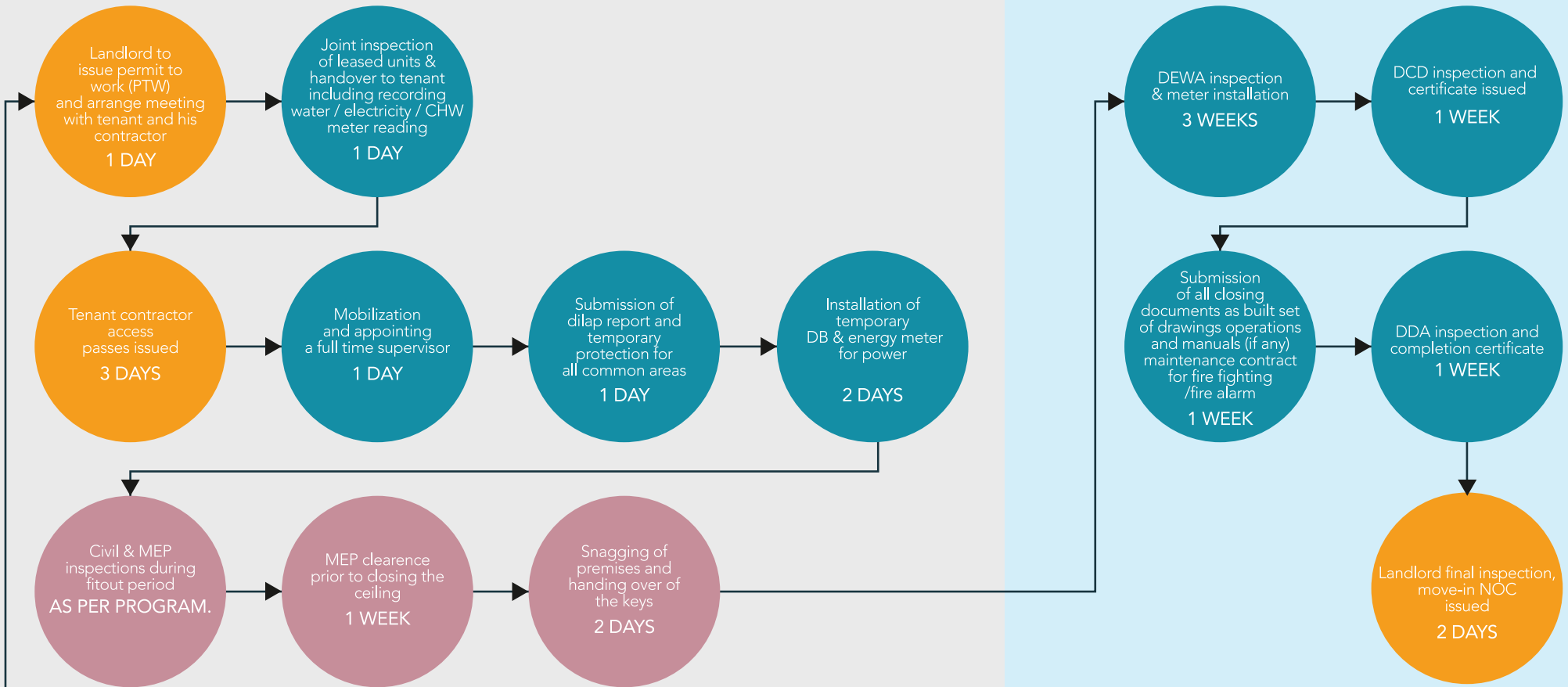

### LEGEND

- Landlord ●
- Tenant ●
- Kling/JLL to FDM ●

## Preferred Contractors for Retail and F&B Projects



Al Tayer Stocks	+971 4 503 4888	<a href="http://www.altayerstocks.com">www.altayerstocks.com</a>
Cubics Interiors	+971 4 335 6422	<a href="http://www.cubicsdesign.com">www.cubicsdesign.com</a>
Havelock One Interiors	+971 4 567 7200	<a href="http://www.havelockone.com">www.havelockone.com</a>
BW Interiors	+971 4 339 2911	<a href="http://www.bwinteriors.ae">www.bwinteriors.ae</a>
Blue Print	+971 4 379 1565	<a href="http://www.blueprintme.com">www.blueprintme.com</a>
Top Rock	+971 4 267 8095	<a href="http://www.toprockinteriors.com">www.toprockinteriors.com</a>

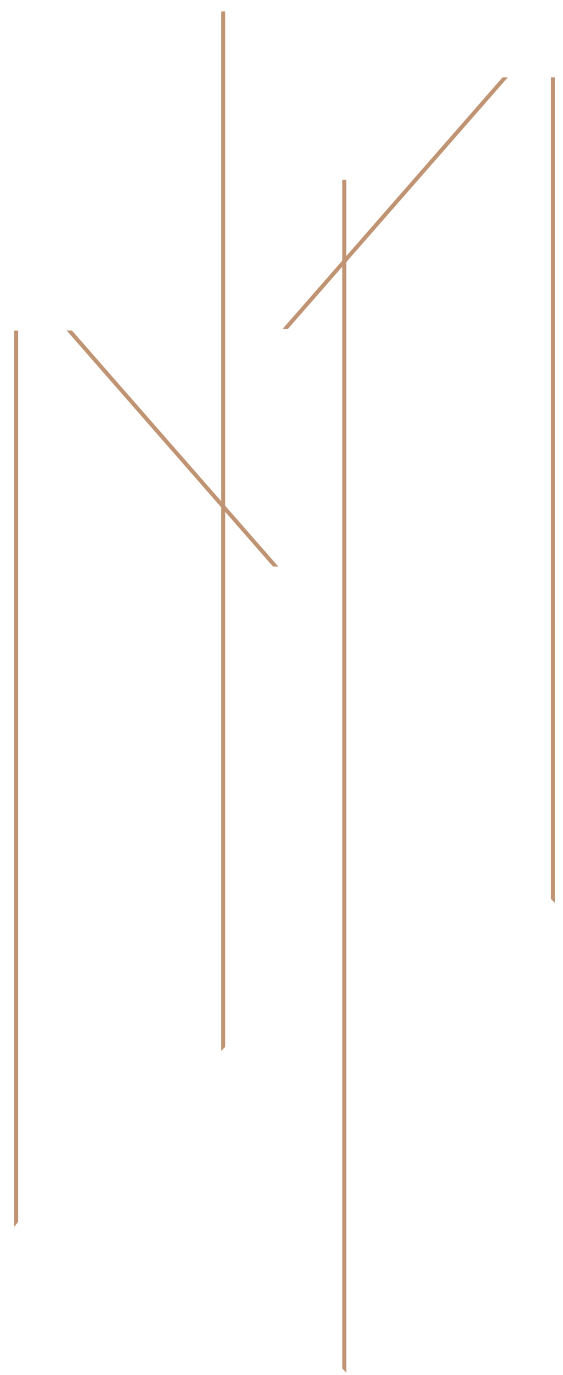

# CENTRAL PARK

TOWERS AT DIFC

---

CENTRAL PARK TOWERS  
800 CPARK (800 27275)  
info@centralparktowers.ae  
centralparktowers.ae

Facebook: @CentralParkInDIFC

Instagram: @centralparkindifc

Twitter: @Central ParkIn DIFC